

Core cross reference (x = material variation within a size)

Fair-Rite: 66XX201621	Micrometals:	Magetics: XX-42016-UG
Nicera:	Epcos:	MMG:
Ferroxcube: PQ 20/16	TDK:	Phillips: PQ 20/16

Winding Area
(mm²)

LODESTONE PACIFIC

B-PQ2016V-14-1-PH3

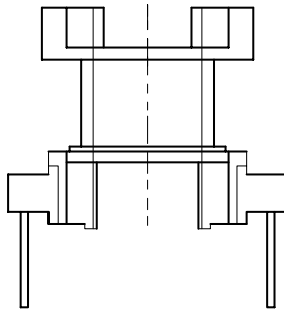
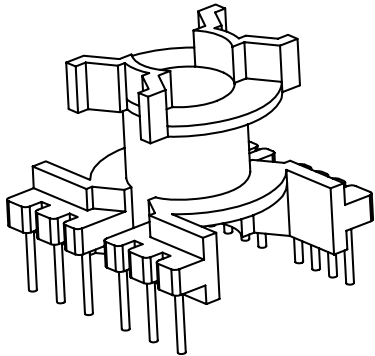

TOP

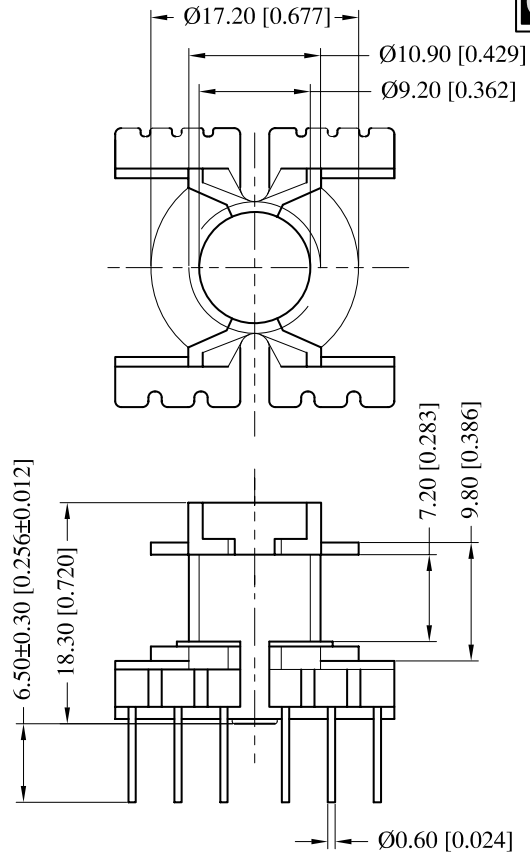

BOTTOM

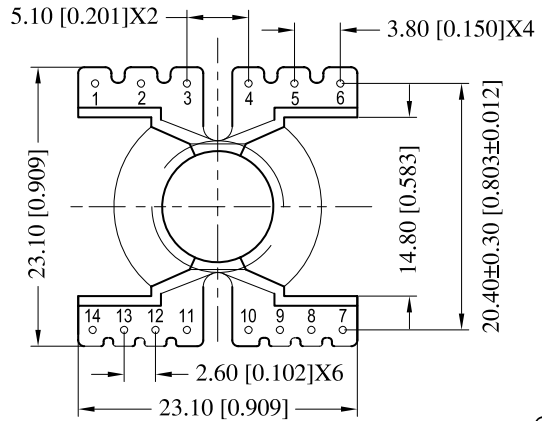
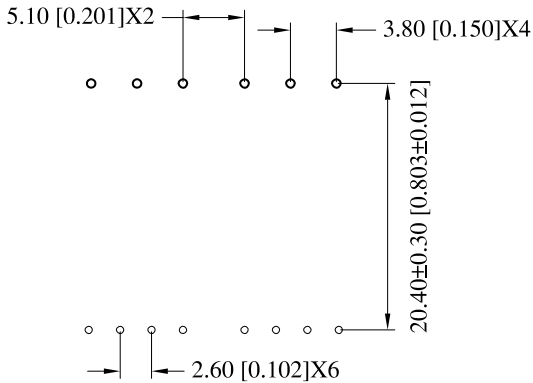

© 2006

	Scale	Tolerance (Inches)	Tolerance (mm)	No. of Terminals	Terminal Plating	Terminal Material	Terminal Type	
	None	.XXX ± .008 .XX ± .012	.XX ± 0.20 .X ± 0.30	14	100% Tin	CP Wire	Through Hole	
LODESTONE PACIFIC					Molding Material	UL File No.	Rating	Class
					Phenolic	E59481	UL94-VO	F
					Lodestone's Part Number		Rev.	
					B-PQ2016V-14-1-PH3		1	

Phone:(714)970-0900.Fax:(714)970-0800
4769 Wesley Drive,Anaheim,California,92807,USA
Web:www.lodestonepacific.com E-Mail:sales@lodestonepacific.com