

Core cross reference (x = material variation within a size)

Fair-Rite: 66XX322021	Micrometals:	Magnetics: XX-43220-UG
Nicera:	Epcos:	MMG:
Ferroxcube: PQ 32/20	TDK:	Phillips: PQ 32/20

Winding Area (mm<sup>2</sup>)

LODESTONE PACIFIC

**B-PQ3220V-12-1-PH3**

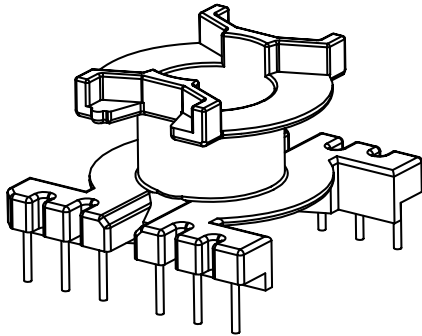

**TOP**

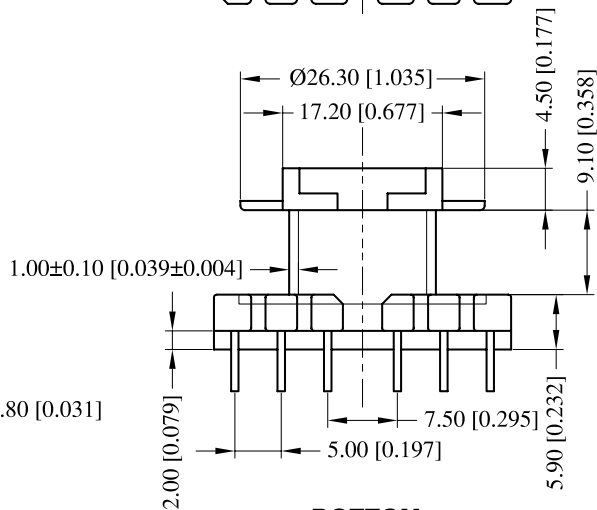
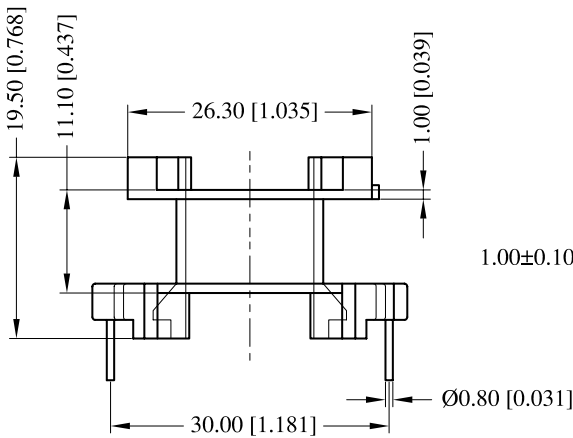
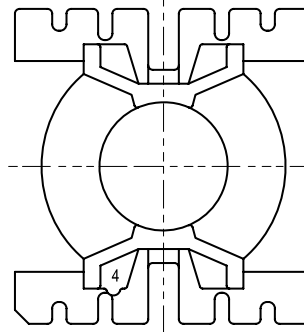

**BOTTOM**

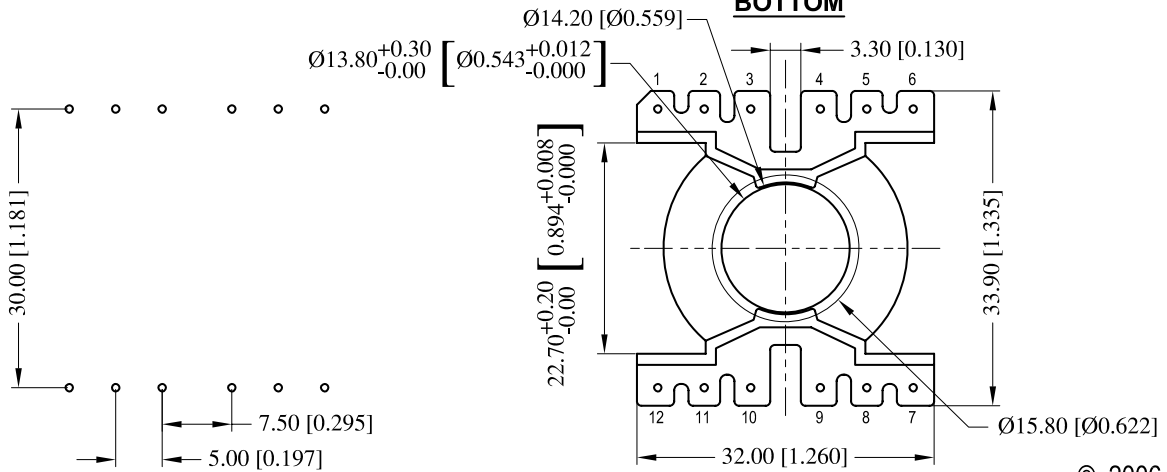

© 2006

	Scale	Tolerance (Inches)	Tolerance (mm)	No. of Terminals	Terminal Plating	Terminal Material	Terminal Type	
	None	.XXX ± .008 .XX ± .012	.XX ± 0.20 .X ± 0.30	12	100% Tin	CP WIRE	Through Hole	
<p style="text-align: center;"><b>LODESTONE PACIFIC</b></p> <p>Phone: (714)970-0900. Fax: (714)970-0800 4769 Wesley Drive. Anaheim, California, 92807. USA Web: www.lodestonepacific.com E-Mail: sales@lodestonepacific.com</p>					Molding Material	UL File No.	Rating	Class
					Phenolic	E59481	UL94-VO	F
					Lodestone's Part Number			Rev.
					<b>B-PQ3220V-12-1-PH3</b>	<b>1</b>		