

Common Mode Inductors for EMI Filters Require Careful Attention to Core Material Selection

Robert West, Magnetics, Division of Spang & Co., Butler, Pennsylvania

The common mode inductor is an integral part of most EMI filters; its very high impedance over a wide frequency range suppresses high frequency power supply spikes.

Switching power supplies generate two types of noise: common mode and differential mode. Differential mode noise (*Figure 1a*) follows the same path as the input power. Common mode noise (*Figure 1b*) is represented by spikes that are equal to and in phase with each other and have a circuit path through ground.

To suppress EMI, a typical filter will include common mode inductors, differential mode inductors and

X and Y capacitors. The Y capacitors and the common mode inductors contribute to the attenuation of the common mode noise. The inductors become high impedances to the high frequency noise and either reflect or absorb the noise while the capacitors become low impedance paths to ground and redirect the noise away from the main line (*Figure 2*). To be effective, the common mode inductor must provide the proper

impedance over the switching frequency range.

Common mode inductors are wound with two windings of equal numbers of turns. The windings are placed on the core so that the line currents in each winding create fluxes that are equal in magnitude but opposite in phase. These two fluxes cancel each other, leaving the core in an unbiased state. The differential mode inductor has only one wind-

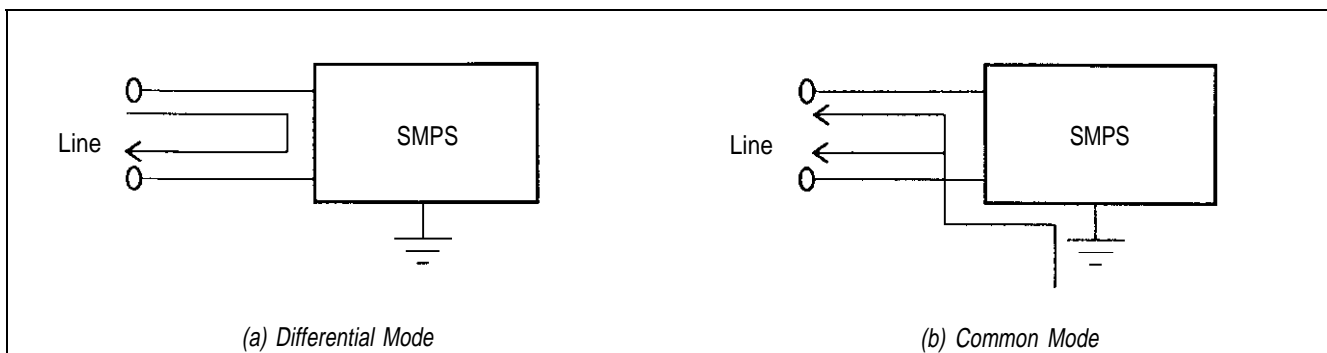

Figure 1. Noise Types.

ing, requiring the core to support the entire line current without saturating. Herein lies the great difference between common mode and differential mode inductors. To prevent saturation, the differential mode inductor must be made with a core that has a low effective permeability (gapped ferrites or powder cores). The common mode inductor, however, can use a high permeability material and obtain a very high inductance on a relatively small core.

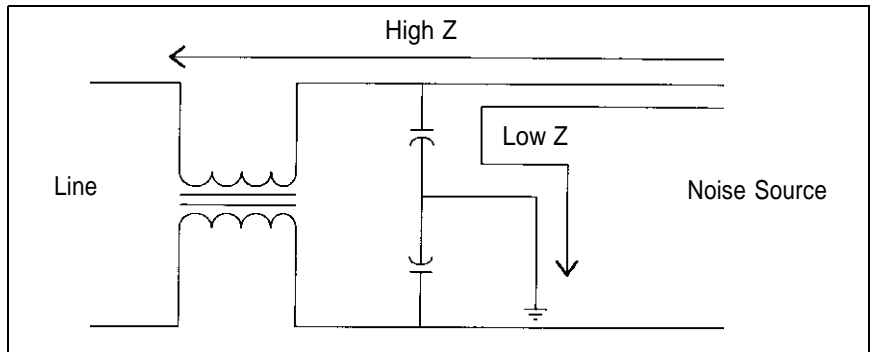

Figure 2. Common Mode Filter.

Material Selection

Noise generated by switching power supplies is primarily at the unit's fundamental frequency, plus higher harmonics. This means that the noise spectrum usually runs anywhere from 10kHz to 50MHz. To provide proper attenuation, the impedance of the inductor must be sufficiently high over this frequency range.

Total impedance of the common mode inductor is composed of two parts, the series inductive reactance (X_S) and series resistance (R_S). At low frequencies, the reactance is the primary contributor to impedance, but as the frequency increases, the real part of the permeability drops and losses within the core rise, as seen in Figure 3. These two factors combine to help produce an accept-

able impedance (Z_S) over the entire frequency spectrum.

For the most part, ferrites are the material of choice for common mode inductors and they are divided into two groups: nickel zinc and manganese zinc. Nickel zinc materials are characterized by low initial permeabilities ($<1000\mu$), but they maintain their permeabilities at very high frequencies ($>100\text{MHz}$). Man-

**Selecting the ideal
magnetic core
can be a problem.**

**MAGNETICS
has the solution!**

One company - **MAGNETICS** - offer the broadest range.

Ferrite Cores: *High frequency materials* (10kHz - 2Mhz) for power transformers and inductors; *High permeability materials* (to 15,000 μ) for EMI filters, ISDN transformers and broadband transformers; and *Temperature stable materials* for telecom applications.

Powder Cores: (*Molypermalloy, High Flux and Kool M μ [®]*): for in-line filters, output chokes and flyback transformers.

Strip Wound Cores: (*Tape cores, cut c-cores, bobbin cores, and laminations*) for high power transformers, audio transformers, magnetic amplifiers, ground fault interrupters and current transformers.

For more information, technical brochures or application engineering assistance, contact:



ganese zinc materials, on the other hand, can attain permeabilities in excess of 15,000 but may start to “roll-off” at frequencies as low as 20kHz.

Because of their low initial permeabilities, nickel zinc materials will not produce a high impedance at low frequencies. They are most often used when the majority of unwanted noise is greater than 10 or 20MHz. Manganese zinc materials, however, offer very high permeabilities at low frequencies and are very well suited to EMI suppression in the 10kHz through 50MHz range. For these reasons, the remainder of this article will focus on the high permeability, manganese zinc ferrites.

High permeability ferrites come in many different shapes: toroids, E cores, pot cores, RMs, EPs, etc.; but for the most part, common mode filters are wound on toroids.

There are two main reasons for using toroids. First, toroids are generally less expensive than the other shapes because they are one piece, whereas other shapes require two halves. When cores come in two halves, they must be flat ground on their mating surfaces to make them smooth and to minimize the air gap between them. Furthermore, high permeability cores often require an additional lapping procedure to make them even smoother (this produces a mirror-like finish). Toroids require none of these extra manufacturing steps.

Second, toroids have the highest effective permeability of any core shape. The two-piece construction of the other shapes introduces an air gap between the halves, which lowers the effective permeability of the set (typically by about 30%). Lapping improves this but does not eliminate it. Because toroids are made as one piece, they do not have an air gap and do not suffer a reduction in effective permeability.

Toroids do have one disadvantage – their high winding cost. Bobbins, which are available for the other shapes, can be wound quickly and

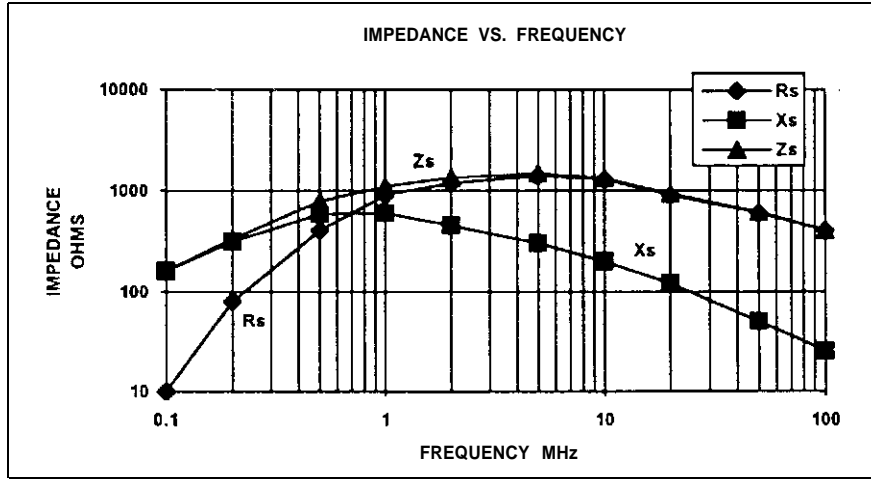

Figure 3. Impedance vs Frequency.

economically. Toroids require special winding machines or must be wound by hand, making the per-piece winding cost higher. Fortunately, the number of turns on common mode inductors is usually quite low, so the winding costs do not become too prohibitive.

For these reasons, toroids are the geometry of choice in common mode inductors and the remainder of this article will focus on their use.

Design Considerations

The basic parameters needed for common mode inductor design are input current, impedance, and frequency. Input current determines the size of the conductor needed for the windings. Four hundred amps per square centimeter is a common design value for calculating wire size, but may be altered depending upon the acceptable temperature rise of the inductor. Single stranded wire is almost always used because it is the least expensive and it helps contribute to the noise attenuation through high frequency skin effect losses.

The impedance of the inductor is normally specified as a minimum value at a given frequency. This impedance, in series with the line impedance, will provide a desired noise attenuation. Unfortunately, the impedance of the line is rarely known, so designers often test their

filters with a 50Ω Line Impedance Stabilization Network (LISN). This has become a standard method for measuring filter performance but it can lead to results that are quite different from those in real life.

A true first order filter will provide an attenuation that increases by -6 dB per octave beyond the corner frequency. This corner frequency is usually low enough so that the inductive reactance is the primary contributor to the impedance, thereby allowing the inductance to be calculated: $L_s = X_s / 2\pi f$.

Once the inductance is known, the remainder of the design involves core and material selections along with the calculations for number of turns.

Quite often, the first step in the design is to select a core size. If the design has physical requirements, then the largest core should be selected that will still stay within these requirements after it is wound. If there are no size restrictions, then a core size can be selected at random.

The next step is to calculate the maximum number of turns that will fit on the core. Common mode inductors require two windings, normally single layer, with each winding on opposite sides of the core to provide isolation. Double layer and bank windings are occasionally used, but they increase the distributed ca-

capitance of the windings and this decreases the high frequency performance of the inductor.

Because the wire size has already been determined by the line current, an inner circumference can be calculated based upon the inner radius of the core minus the radius of the wire. The maximum number of turns can then be calculated by dividing the wire diameter, with insulation, into that portion of the circumference occupied by each winding. Note: Allowing for isolation between the windings, each winding will typically occupy 150° to 170° of the inner circumference.

Once the maximum number of turns have been calculated, the next steps are to choose a material and determine the inductance. Material choice involves many factors; operating temperature, frequency range and cost, to name a few. However, the first issue is to verify the core size that was selected; the other factors can be resolved later. To do this, a moderate permeability material should be chosen and the inductance calculated.

Most ferrite manufacturers list inductance factor (A_L) values for their cores, which provides an easy method for calculating the inductance. The relationship between the number of turns and inductance is:

$$N=1000 (L/A_L)^{1/2}$$

where:

N = Number of turns

L = Inductance (mH)

A_L = Inductance factor in mH/1000 turns

Table 1 lists typical design information and an example calculation using the A_L value.

For this example:

J material (5000 μ) is chosen with an A_L value of 3020

N is given as 20 turns, so:

$$L = 1.208\text{mH}$$

If this minimum inductance is too low for the design, then a higher permeability material, or a larger core, can be selected. However, if the calculated inductance is well above the design limit, then a smaller core with fewer turns could possibly be substituted.

DESIGN EXAMPLE:

An impedance of 1000 Ω is needed at 10kHz. RMS input line current is 3A.

1. Choose wire size:

3A at 400 A/cm² yields a wire area of 0.0075cm²

#19 AWG is chosen with a wire area of 0.007907cm² (1 mm diameter), including insulation

2. Calculate minimum inductance:

$$L \text{ minimum} = 100\Omega / 2\pi(10,000 \text{ Hz}) = 1.59\text{mH}$$

3. Choose a core size and material from the table:

J-42206-TC is chosen

$$A_L = 3020 \pm 20\%$$

Inside diameter = 13.72mm
±0.38mm = 13.34mm minimum

4. Calculate inner circumference (I.C.) and maximum number of turns possible:

$$I.C. = \pi (\text{core diameter} - \text{wire diameter})$$

$$I.C. = \pi (13.34\text{mm} - 1 \text{ mm})$$

$$I.C. = 38.76\text{mm}$$

$$\text{Maximum turns} = (160^\circ/360^\circ) * (38.76\text{mm})/(1\text{mm/turn})$$

$$I.C. = 17.2 \text{ turns, or } 17 \text{ turns}$$

5. Calculate minimum inductance for 17 turns:

$$A_L = 3020 \pm 20\%$$

$$N = 1000 (L/A_L)^{1/2}$$

$$17 = 1000 (L/3020 - 20\%)^{1/2}$$

$$L = 0.698 \text{ mH minimum}$$

The resulting value is considerably lower than the 1.59 mH needed, so a modification must be made. The options available for change are core size, material permeability and wire size. A larger core will provide a bigger inside diameter so more turns can be wound on the core (larger cores may also have a higher A_L value). A higher permeability material will, naturally, raise the inductance and a smaller wire size will allow more turns to fit on the core (but this will also increase the copper losses).

Continuing with the previous example, if it is decided to keep the 42206-TC size, then new turns calculations must be made for each material.

Table 1 lists typical design information and an example calculation using the A_L value.

Core Type	O.D. (mm)	I.D. (mm)	Height (mm)	A_L (mH/1000 turns)			I_e (cm)	A_e (cm ²)	V_e (cm ³)
				J 20% (5000 μ)	W 30% (10,000 μ)	H 30% (15,000 μ)			
42206-TC	22.1	13.72	6.35	3020	6040	9060	5.42	0.250	1.36

J material (5000 μ):N = 1000
 (1.59mH/3020-20%)^{1/2} = 25.6 turns

W material (10,000 μ):N = 1000
 (1.59mH/6040-30%)^{1/2} = 19.4 turns

H material (15,000 μ):N = 1000
 (1.59mH/9060-30%)^{1/2} = 15.8 turns

If the J material is used, then a smaller wire size is definitely needed, whereas the original wire size should fit nicely on the H material. The turns required for the W material are only slightly greater than the maximum calculated previously in step 4 (17 turns). Sample windings should be tried on this core to determine if a smaller wire size is necessary.

The steps mentioned above for core selection can be quite time-consuming. To speed the selection process, a "Core Selector Chart" is given in Figure 5. To use it, simply multiply the RMS line current by the required inductance (in mH), and locate this point on the abscissa. Move up the chart until the appropriate diagonal material line is crossed, then continue upwards until the very next horizontal "size" line is reached. This line corresponds to a certain core size located on the ordinate of the graph. J, W and H materials are included on the chart. Naturally, H material yields the smallest core sizes.

This graph assumes a current density of 400A/cm² and single layer windings on the core. Using different current densities will require some guesswork (the W μ line can be used for J μ at 200A/cm²). This chart is only meant as an aid to core selection; the final design may be slightly larger or smaller.

Frequency Characteristics

The design method just described provides core size and material, but it leaves out many other details that must also be covered. For instance, common mode filters operate over very wide frequency ranges (government regulations on EMI extend to 30MHz), so material performance

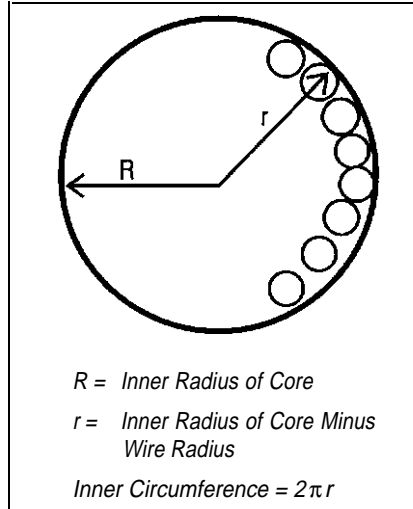

Figure 4. Toroid Inner Circumference.

frequency increases. The higher the permeability, the lower the frequency where this roll-off occurs. Fortunately, these materials also become very lossy at high frequencies, and these resistive losses keep the total impedance of the inductor high, out beyond 100MHz. Figures 6 and 7 show how the series inductive reactance (X_s) and series resistance (R_s) change over frequency for the three high permeability materials (J, W and H). Figure 8 displays the total impedance versus frequency for each material. The measurements were made with 10 turns on 42206-TC size cores.

The graphs indicate that H material has a distinct advantage over W and J at low frequencies. However, between 100kHz and 200kHz its permeability has dropped low enough so that the total impedance has fallen below the W material im-

beyond the corner frequency must be understood.

Manganese zinc ferrites exhibit high permeabilities at low frequencies (<500kHz), but roll-off as the

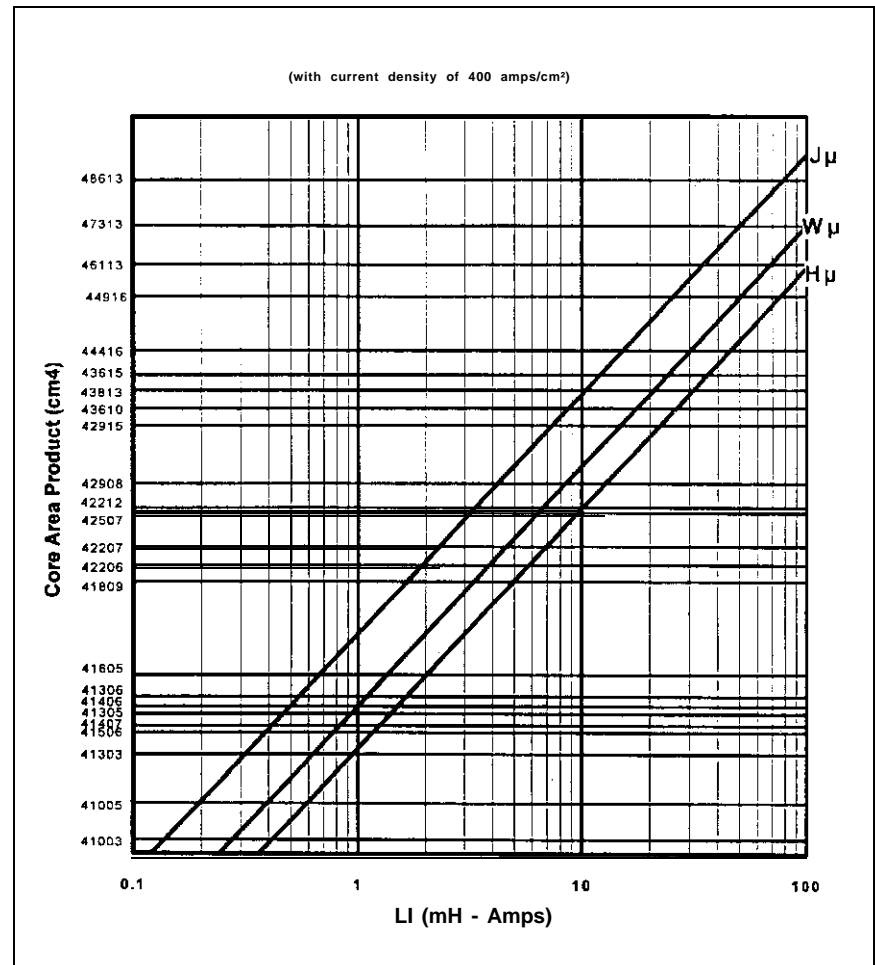

Figure 5. Common Mode filter Core Selector Chart.

pedance. The W material then has the highest impedance until 2MHz, where the J material takes over. Curves such as these can help the designer to select the proper mate-

rial when the frequency spectrum of the noise is known.

Temperature has an effect on most ferrite material properties. Of primary interest to the common mode

choke designer are the effects versus permeability and flux density. Most materials increase in permeability as the temperature increases. *Figure 9* shows the curve for W material. Likewise, a decrease in permeability should be expected when the temperature goes below 25°C. Worst case permeability fluctuations must be taken into account when designing for the minimum filter inductance. Temperature also affects saturation flux density. *Figure 10* shows W material's typical decrease in flux density with increasing temperature. This reduction in usable flux density can increase the likelihood of core saturation.

In addition, all magnetic materials have a Curie temperature, the point where magnetic activity stops. High permeability ferrites usually have Curie temperatures between 120°C and 175°C. It is important to know where this Curie point is and to maintain the core operating temperature below this limit. Ferrites are not damaged if the Curie temperature is exceeded (i.e. during wave soldering), but they will become non-magnetic if the Curie temperature is reached during operation.

Finally, ferrite toroids are frequently offered with a dielectric coating (i.e. parylene, epoxy, etc.) to help insulate the core from the windings. These coatings have their own temperature ratings and can be damaged by the combination of heat and strong cleaning agents used during the assembly process. Manufacturers' data books should always be consulted for the appropriate information on core coatings, as well as the other material properties mentioned earlier.

Ferrite materials are susceptible to mechanical stress, both compressive and tensile. High permeability materials are particularly affected and can exhibit large, negative changes in permeability under moderate stresses. There are two major causes of core stress: encapsulants and windings.

An encapsulant causes stress if it has a thermal coefficient of expan-

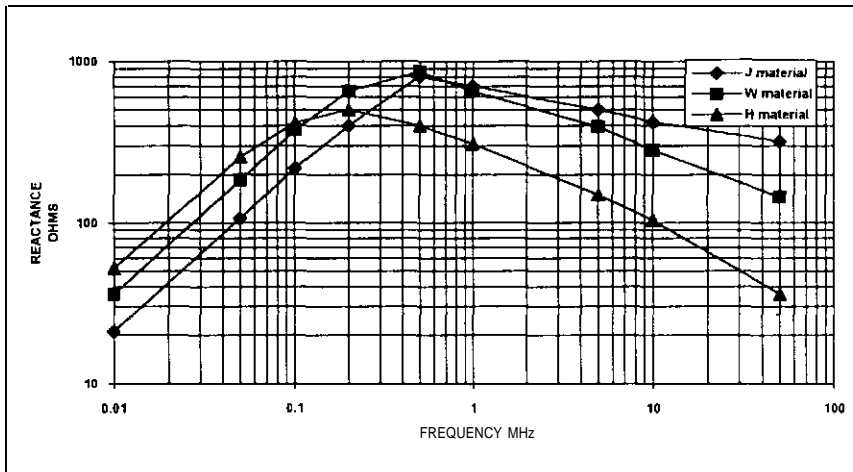

Figure 6. Series Reactance vs Frequency.

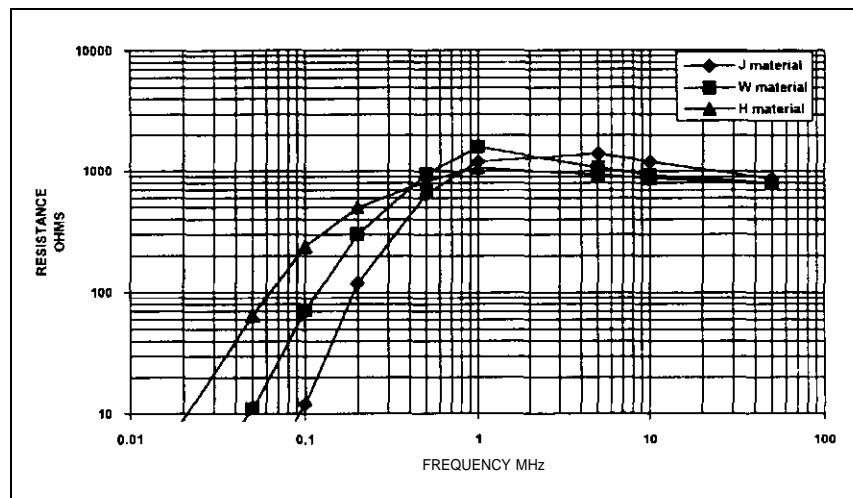

Figure 7. Series Resistance vs Frequency.

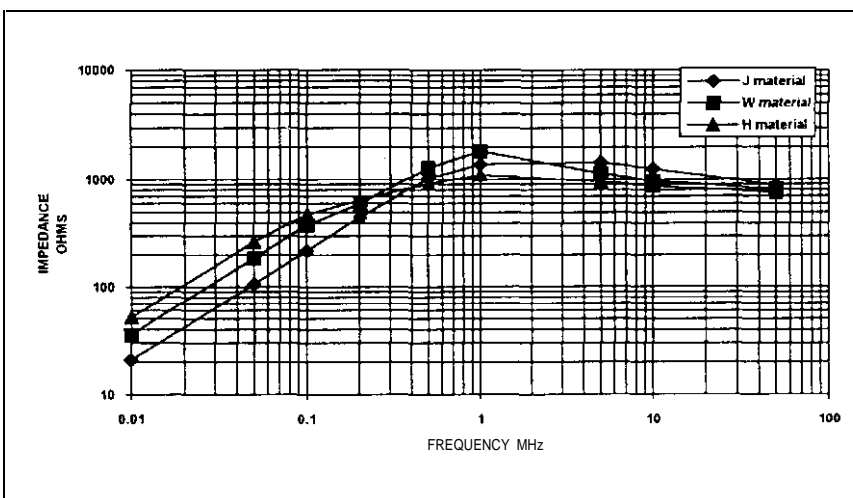

Figure 8. Total Impedance vs Frequency.

sion that is different from the ferrite. Encapsulants should be chosen with expansion coefficients as close to the ferrite as possible, but even small differences can cause problems. Therefore, one possible remedy is to cushion the core with a “rubbery” material, like RTV, before it is potted. This coating can help to distribute some of the stress caused by the encapsulant during temperature fluctuations.

Winding stress occurs when the wire is wound onto the core. Common mode inductors are usually wound with rather heavy conductors and these wires must be pulled tight in order to fit properly around the core. The stress induced can be quite severe. Temperature cycling normally relieves most winding stresses. The cycle should range from -55°C to $+150^{\circ}\text{C}$, with both extremes maintained for 30 minutes to 1 hour. The rate of change should only be a few degrees per minute to prevent a thermal shock (cracking) to the ferrite. During the process, the copper wire will expand and contract, thereby relaxing the force exerted on the core.

To show the effects of stress on ferrites, inductance measurements were made on four toroids of different permeabilities (3000μ , 5000μ , $10,000\mu$, $15,000\mu$) as tensile forces were exerted upon them. The results are given in *Figure 11*, as percent of initial permeability versus force per core cross-sectional area. As expected, the 15,000 permeability material had the greatest reduction in permeability while the 3,000 permeability material had the smallest.

Core Saturation

Popular opinion states that common mode inductors cannot be saturated; the differential mode flux within the core cancels and the common mode flux is so low that it is not a concern. Unfortunately, this is not entirely true. It has been shown by others^[4,5] that some amount of differential flux exits the core from each winding. This leakage flux is proportional to both the line current

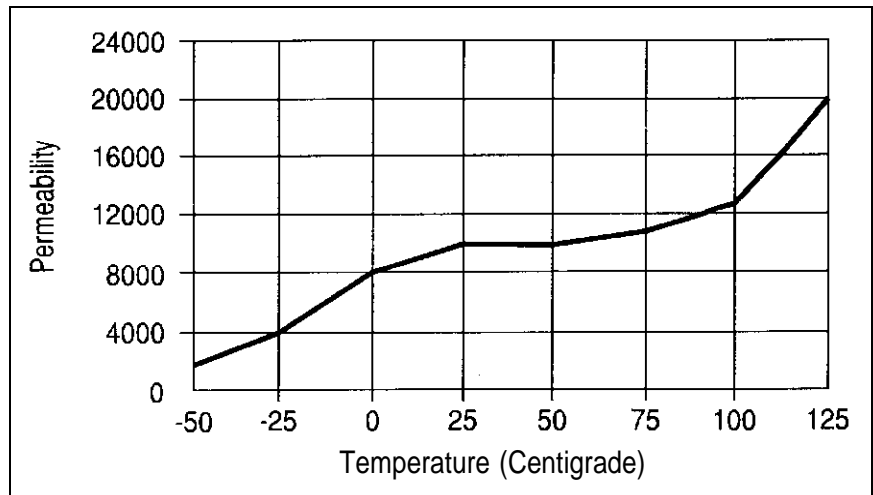

Figure 9. Permeability vs Temperature.

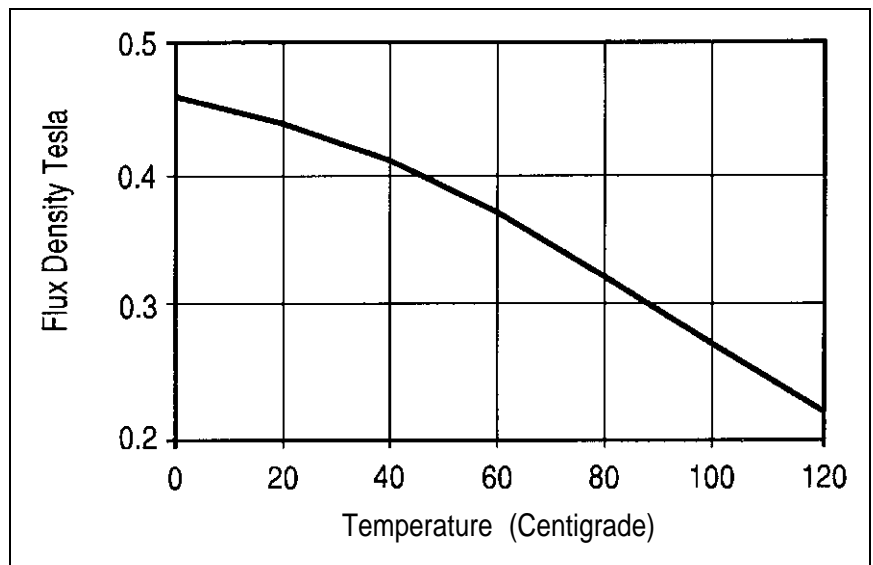

Figure 10. Flux Density vs Temperature.

and the leakage inductance of the winding. Because the leakage flux leaves the core and is not canceled, it is possible for it to saturate the core material under high line currents, or at least shift the point of operation away from the origin of the BH loop to a point of lower incremental permeability ($\mu\Delta$). This lowering of the permeability results in a proportional decrease in series inductive reactance (X_L) and could allow unwanted noise to pass through the filter.

The problems of core saturation are exacerbated in switching power supplies that do not provide power factor correction. High capacitor charging currents with crest factors

that are three to four times greater than the RMS current can easily saturate the core, again allowing common mode noise to pass (*Figure 12*). Also, as mentioned earlier, high operating temperatures intensify these problems by lowering the saturation flux density.

To show the effects of core saturation, three cores (one core of each material, J, W and H) were wound like a common mode filter. Each core had two windings of 15 turns of #18 AWG. A third winding of 10 turns was put on the core and connected to an inductance analyzer. The common mode windings were then connected in series so that any

current through them would create opposing fluxes. These windings were then connected to a DC power supply. Inductance was measured on the 10 turn winding as the DC current was increased from 0 to 15A. The DC current simulated the in-

stantaneous line current that passes through common mode inductors. As can be seen from *Figure 13*, all the cores dropped in inductance as the current increased. The J and W materials were reduced by the same percentage at 10 and 15A (10% and

24%, respectively), while the H material dropped a little further (15% and 35%).

These results show that the common mode inductance is affected by the leakage inductance and that core saturation is possible under peak line currents. If it is found that an inductor is experiencing partial core saturation, then a switch to a higher permeability material may be needed. A higher permeability will offset the effects of core saturation by providing a greater starting inductance, as shown in *Figure 13*, or will reduce the level of saturation by allowing a reduction in the number of turns, thereby lowering the leakage inductance. Different core sizes and winding techniques are other methods that can reduce leakage inductance.

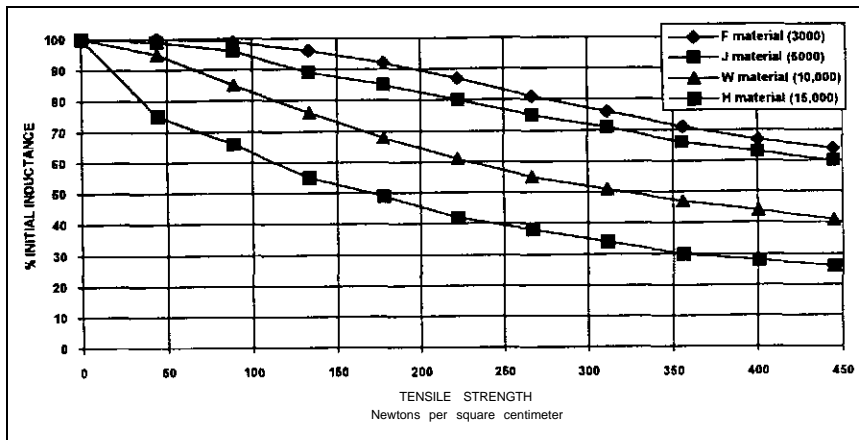

Figure 11. Inductance vs Tensile Strength.

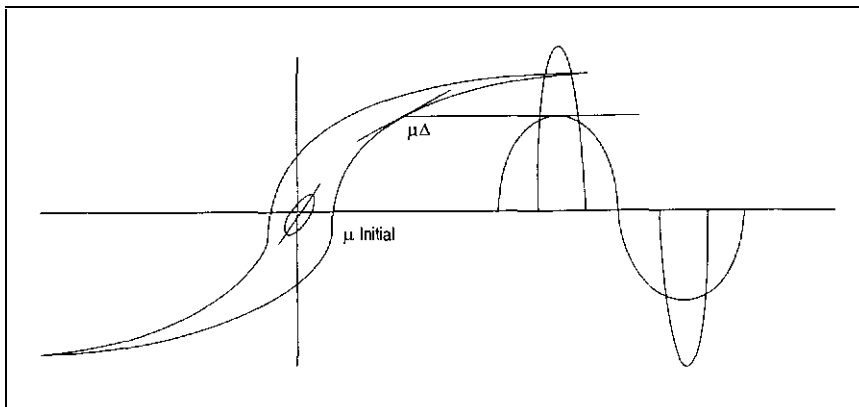

Figure 12. Core Saturation B-H Curve Due to High Crest Factor.

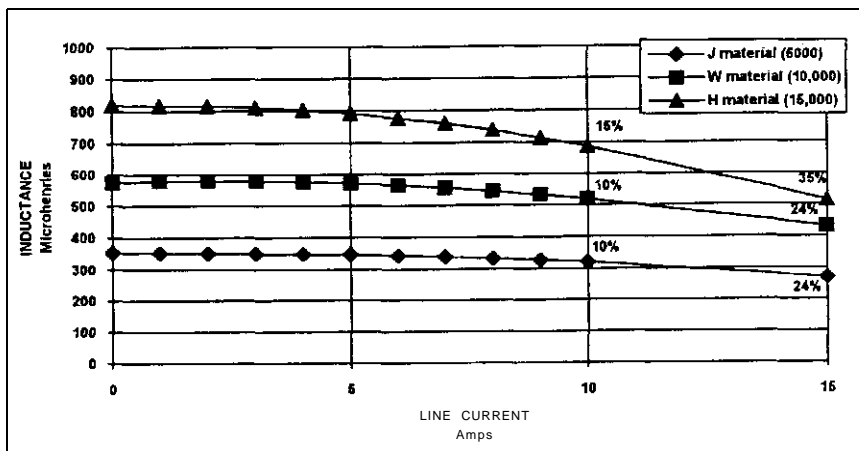

Figure 13. Inductance vs Line Current.

References

1. MAGNETICS Technical Bulletin, FC-S2, 1994.
2. MAGNETICS Ferrite Core Catalog, FC-601, 1994.
3. Srebranig, Steven and Leonard Crane, *Guide for Common Mode Filter Design*, Coilcraft Publication, 1985.
4. Nave, Mark, *On Modeling the Common Mode Inductor*, Publisher and Date Unknown.
5. Nave, Mark, *A Novel Differential Mode Rejection Network for Conducted Emissions Diagnostics*, IEEE, 1989.
6. Crane, Leonard and Steven Srebranig, *Common Mode Filter Inductor Analysis*, Coilcraft Publication, 1985.
7. Knurek, D.F., *Reducing EMI in Switch Mode Power Supplies*, IEEE, 1988.

©1995 from PCIM magazine, reprinted from July 1995 issue.