

LODESTONE PACIFIC

"Finest In The Field"



VARIABLE SHIELDED COIL FORMS

Hardware Only or Finished Wound Assemblies
For Tunable Inductors, Transformers and Oscillators



- THROUGH HOLE
- SURFACE MOUNT

Issue L
Rev. 1

4769 Wesley Dr., Anaheim, CA 92807 USA • Phone (714) 970-0900 • Fax (714) 970-0800

E-Mail: sales@lodestonepacific.com • www.lodestonepacific.com

Tuneable Shielded Coil Forms

High Q • Dependable Performance • Superior Temperature Stability • RoHS and REACH Compliant

"Finest in the Field"

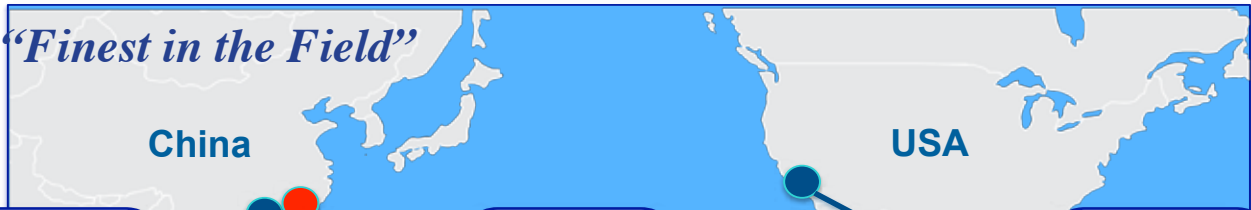

yina@lodestonepacific.com
+(86) 188 2338 3349

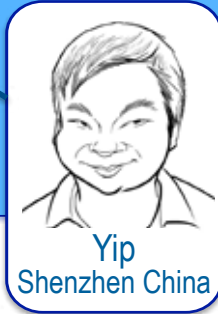

yip@lodestonepacific.com
+(86) 137 9449 8541



karin@lodestonepacific.com
+1(800) 694-8089

From Fish Finder to Sidewinder

Variable Shielded Coil Forms for making Variable Inductors, IFT Coils, Oscillators, RF Coils, Transformers, RF Filter Inductors, Narrow and Broadband RF Transformers, AM and FM OSC Coils, RF Antenna Coils, TV Receiver Coils, Transceiver Coils, and IFT Amplifiers.

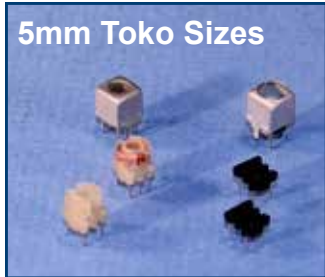

Lodestone Pacific Popular Assemblies

High Q • Great Temperature Stability USA Military Qualified

- 8mm Assemblies Using Iron Powder Cores
Lodestone L32, L33, L335 & L337 series
- 10.5 & 11mm Assemblies Using Iron Powder Cores
Lodestone L42, L41, L43 series
- 11.5 & 14.5mm Assemblies Using Iron Powder Cores
Lodestone L45, L57 series

Popular Millimeter (mm) Sizes

Toko Sizes and Configurations

- 5mm Assemblies Using Ferrite Cores
Lodestone L20 series, Toko Equivalent: 5K
Lodestone L28 series, Toko Equivalent: 5P
- 7mm Assemblies Using Ferrite Cores
Lodestone L30 series, Toko Equivalent: 7KLL
Lodestone L38 series, Toko Equivalent: 7P
- 10mm Assemblies Using Ferrite Cores
Lodestone L40 series, Toko Equivalent: 10K
Lodestone L48 series, Toko Equivalent: 10EZ

Custom Wound Inductors and Transformers

Popular Toko Sizes Wound to Your Specifications.

- 5mm, 7mm and 10mm
- Wound to the Customers L and Q Specifications
- Capacitors in Base to Tune Self-Resonant Frequency



Cage Code OJWUI



All Catalog Parts
ITAR Compliant

Proud Member



NEW! REACH Docs Database

Search for REACH documents, view or download the certifications .pdf.
www.lodestonepacific.com/reach.php

Check Inventory

View daily updated inventory levels in USA and Hong Kong warehouses.
www.lodestonepacific.com/search.php

NEW! Find a Coil Winder

Search our Coil Winder Data Base, for capabilities to match your specs.
www.lodestonepacific.com/coilwinders.php

Request a Quote

Request a quote and delivery and have it e-mailed to you same day.
www.lodestonepacific.com/quote.php

Performance of Variable Shielded Coil Forms

The quality and characteristics of the magnetic field generated in a variable inductor is determined by the quality and shape of the magnetic core materials, and by the characteristics of the winding. A cylindrical core in the center of a spring wound wire coil form will create a magnetic field with invisible lines of flux represented by Figure 1. The construction of the Shielded Coil Form traps and channels a majority of the magnetic lines of flux within a magnetic path-way created by the cup, increasing the efficiency and performance of the assembly as represented by Figure 2. The more complete the magnetic pathway along the magnetic lines of flux, the higher the inductance and the quality (Q) of the assembly. Some magnetic flux will escape the core material enclosure, but will be contained by the copper or brass (tin plated) shield can that covers the assembly.

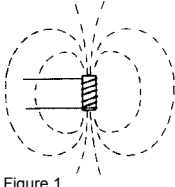

Figure 1

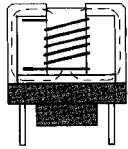

Figure 2

Variable Shielded Coil Forms are generally available with the magnetic core materials in two configurations: a threaded center core tuning within a winding form surrounded by a fixed cup as shown in Style 1, or a winding on a fixed drum core surrounded by a tunable cup as shown in Style 2. The optimum state for a tuned inductor is to have the desired inductance reached when the tuning core or cup fills the center core gap in the assembly and closes the magnetic field.

The Inductance of the Assembly: The inductance (L) is listed in μh (micro-henries) for 100 turns on the data sheets for each Shielded Coil Form (SCF) assembly. Starting with the 100 turn inductance, the number of turns of wire required for a desired inductance can be calculated from the following formula.

$$\text{Required Turns} = 100 \sqrt{\frac{\text{Desired L } (\mu\text{h})}{\text{L } (\mu\text{h}) \text{ for 100 Turns}}}$$

The inductance of each assembly is fairly flat with increasing frequency until after the peak of that assembly's Q. Above the peak Q frequency, apparent inductance will climb with frequency until the frequency when self resonance occurs. The inductances shown in this catalog are measured at frequencies below the Q curve's peak

MIX NUMBER	COLOR CODE	MAGNETIC MATERIAL	MATERIAL PERMEABILITY	FREQUENCY RANGE	TEMPERATURE STABILITY
1	BLUE	CARBONYL C	20	.15-2.0 MHz	280 ppm/°C
2	RED	CARBONYL E	10	.25-10 MHz	95 ppm/°C
3	GRAY	CARBONYL HP	35	.02-1.0 MHz	370 ppm/°C
3F	ORANGE	HP/FERRITE	80	.01-1.0 MHz	700 ppm/°C
6	YELLOW	CARBONYL SF	8.5	2.0-30 MHz	35 ppm/°C
10	BLACK	CARBONYL W	6.0	10-100 MHz	150 ppm/°C
17	LAVENDER	CARBONYL W	4.0	20-200 MHz	50 ppm/°C
50	ORANGE	FERRITE 50	125	.01-1.0 MHz	1500 ppm/°C
51	NONE	FERRITE 51	300	.05-2.0 MHz	1500 ppm/°C
52	NONE	FERRITE 52	60	2.0-200 MHz	1500 ppm/°C
53	NONE	FERRITE 53	44	.05-20 MHz	1500 ppm/°C
54	NONE	FERRITE 54	25	5.0-300 MHz	1500 ppm/°C

High Performance Tunable Shielded Coil Forms (SCF)

- Toko Equivalent Hardware
- Superior Temperature Stability
- RoHS and REACH Compliant Materials
- Quality Inspection to MIL-STD-1916 Level IV
- Un-wound Hardware or Complete Wound Coils
- For RF Filter Inductors, IFT Oscillators, and Transceivers

Variable Shielded Coil Form Hardware Example Part Number

L45-10-PCT-B-4

Assembly Code
 L20 5mm Style 1
 L28 5mm Style 2
 L30 7mm Style 1
 L32 8mm Style 1
 L33 8mm Style 1
 L335 8mm Style 1
 L337 8mm Style 1
 L38 7mm Style 2
 L40 10mm Style 1
 L41 10mm Style 1
 L42 10.5mm Style 1
 L43 11mm Style 1
 L45 11.5mm Style 1
 L48 10mm Style 2
 L57 14.5mm Style 1

Material Type
Iron Powder
 1; .15-2 Mhz
 2; .25-1.0 Mhz
 3; .02-1.0 Mhz
 6; 2.0-50 Mhz
 10; 10-100 Mhz
 17; 20-200 Mhz
Ferrite
 51; .05-2.0 Mhz
 52; 2.0-200 Mhz
 53; .02-20 Mhz
 54; 5.0-300 Mhz

No. of Terminals
2,4,5,6

Winding Form
 F-Coil Form Tube
 B-Molded Bobbin
 D-Drum Core

Shield Can
 CT-Copper, 100% Tin Plate
 PCT-Copper, 100% Tin Plate w/Vibration Pad
 BT-Brass, 100% Tin Plate

Tuned Core
 Fixed Cup

Style 1

Drum Core
 Tuned Cup

Style 2

Custom Wound Variable Coils

Example Part Number

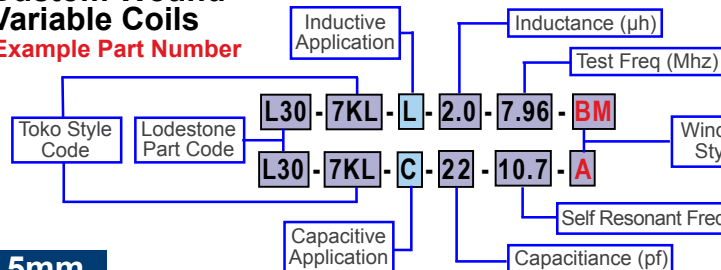

5mm

7mm

10mm

Custom Variable Shielded Coils are wound to:
 1) Your Inductance, Frequency and Q Specifications, or
 2) With Internal Capacitors to your Self-resonant Frequency Specifications.

Test Frequencies (Mhz): 25.2 (0.1 to 1 μh), 7.96 (1 μh to 10 μh), 2.52 (10 to 100 μh), .796 (100 μh to 1mh), .252 (1mh to 10mh)

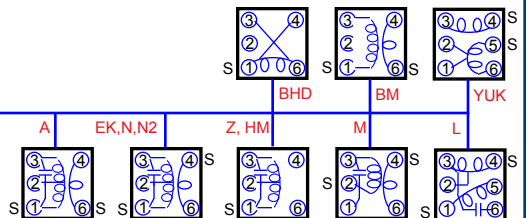

Internal Capacitors (pf): Selected to meet the specified self-resonant frequency

The Q of the Assembly

The optimum Q (quality or efficiency) of an assembly is found in balancing the fundamental physics of both the core material and the winding. The assembly's contribution to superior Q is found in the core materials shape, inductance and frequency sensitivity. The winding's contribution is maximized by minimizing frequency specific wire losses in the winding. The key to optimising the Q of the assembly is selecting the proper core material, wire and winding characteristics, for a particular frequency .

Core Considerations

The iron powder and ferrite materials used in Lodestone Pacific's Shielded Coil Forms are formulated for optimum Q within a specific frequency range as shown by the table on Page 3. The Q vs. frequency curves on these pages show the highest Q's achievable for a particular core material and frequency. The shape and magnitude of these curves can be characterized by the following formula:

$$Q = \frac{2\pi fL}{R}$$

Where f is frequency in Mhz, L is inductance in μ h and R is the effective series resistance due to both copper and core loss in ohms. While the frequency and inductance is known or calculated, the frequency sensitive copper and core material losses are often difficult to calculate. In addition, variations in core material density and winding characteristics often make the Q experienced in actual applications differ from theory.

The Q vs frequency curves included in this catalog are plotted on a semi-log axis and were derived from actual testing of the variable assemblies in a parallel resonant circuit and reflect the expected Q readings with a specific inductance and winding. As the frequency is varied, the readings will

trace a humped curve identifying the optimum inductance-frequency balance that produces the highest Q. Increasing inductance by adding turns of wire or tuning the core towards the maximum inductance position will create a new Q curve with a peak that will be shifted down in frequency. Conversely, reducing inductance by decreasing turns or de-tuning the assembly will shift the Q curve peak towards a higher frequency.

Figure 3 shows the L57-2-PCT-B-4 assembly wound with a decreasing numbers of turns. The family of Q curves show the trend towards higher frequency Q curves as you reduce inductance by reducing turns. It also shows that the maximum value of each Q curve will diminish as the curve peaks move to the extremes of their recommended frequency ranges. There is an optimum frequency and inductance for a given assembly where the "peak of the peaks" will occur (at 1.5 Mhz in Figure 3). This is why applications requiring high Q are best engineered with the inductive portion of the tuned circuit optimised first, and the capacitor specified to support that optimum Q.

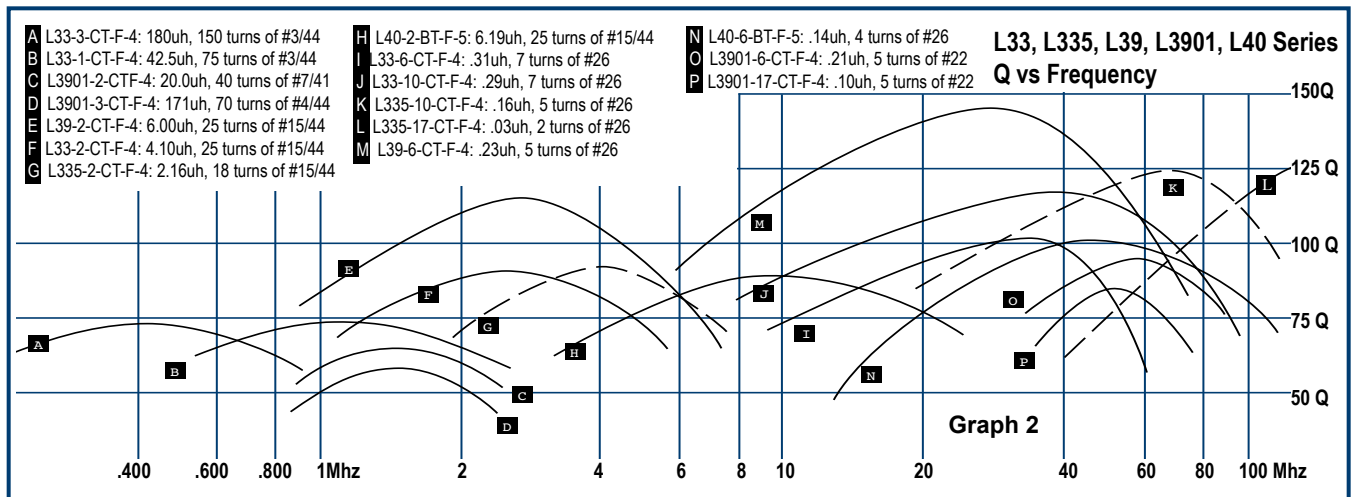
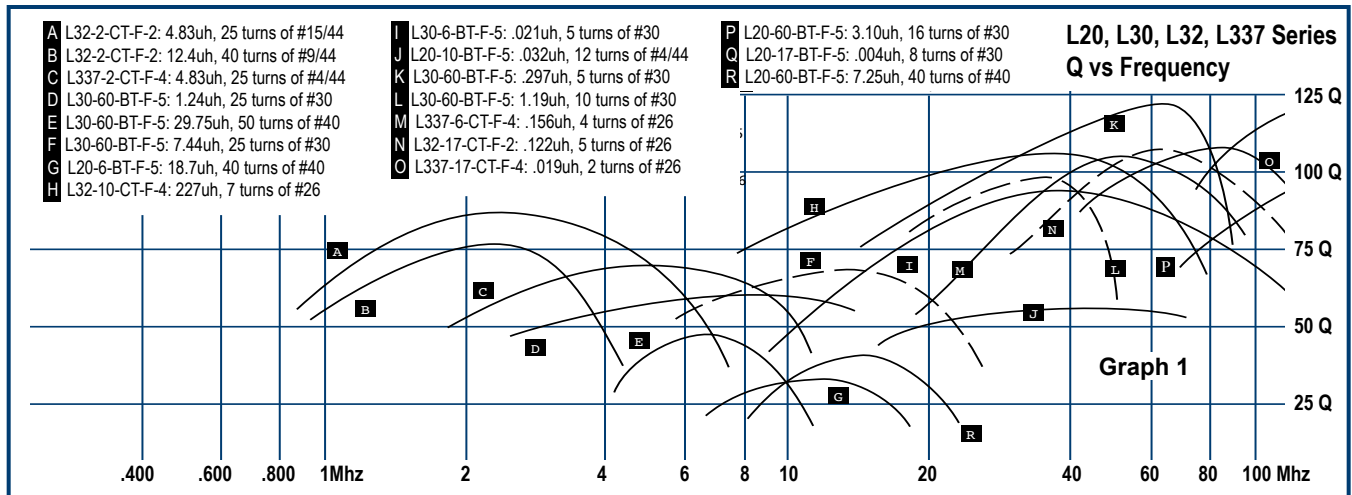
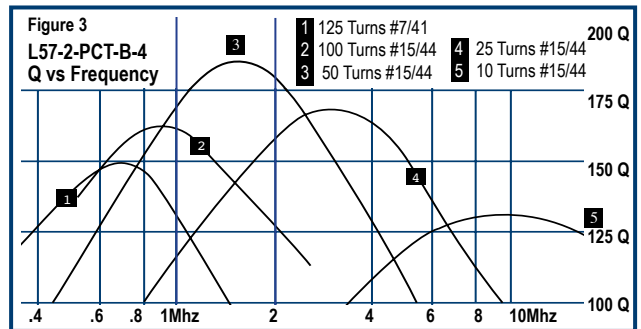

Each core material formulation will produce similar families of curves within their optimum frequency ranges. The complete family of Q curves for the L57 series on Graph 5 show that mix formulations 6 exhibits better Q characteristics as the frequency moves above formulation 2's optimum frequency range.

The amount of core material in the assembly will also improve Q. As an example, the L57-2-CT-B-4 wound with 25 turns of 15/44 Litz wire (Graph 5, curve F) will produce higher Qs than the L45-2-CT-B-4 with the same winding (Graph 4, curve E). This is due to 28% more iron powder in

the larger L57 assembly. Comparing the L337-2-CT-B-4 (Graph 1, curve C), L33-2-CT-F-4 (Graph 2, curve F) and L45-2-CT-B-4 (Graph 4, curve E) shows the relative Q of these assemblies with 25 turns of 15/44 Litz wire at approximately 2 Mhz.

In comparing these curves it can be seen that increasing the amount of core material also shifts the "peak of peaks" down in frequency. As an example, the L57-2-CT B-4 (4.45 grams of core material) with 25 turns of 15/44 peaks at 1.5 Mhz (Graph 5, curve F), while the smaller L33-2-CT-B-4 with the same winding and only .601 grams of core material peaks at 2.3 Mhz.(Graph 2, curve F).

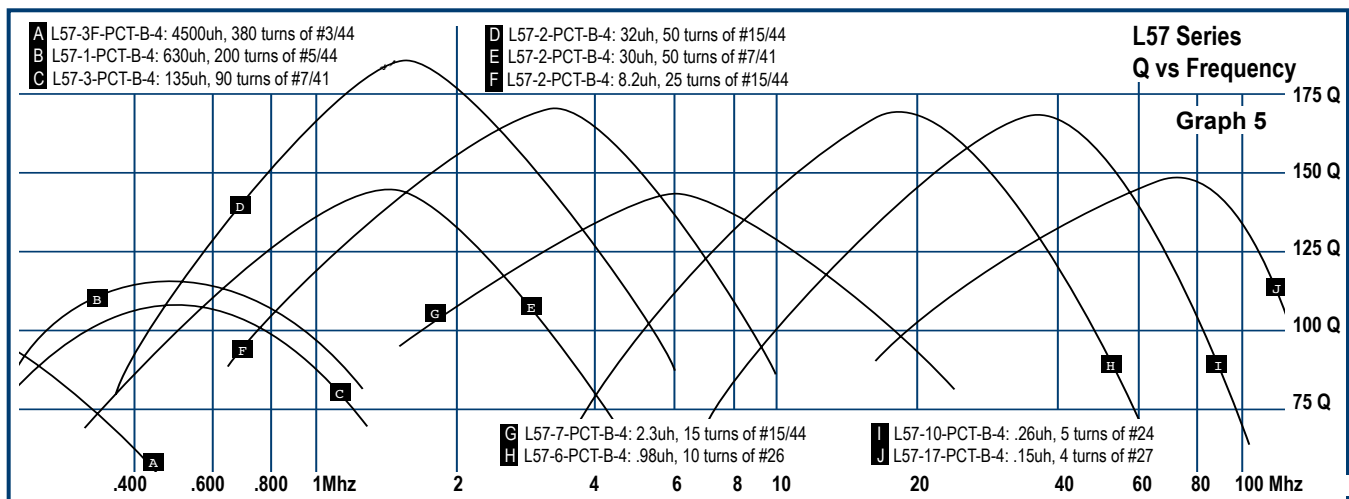
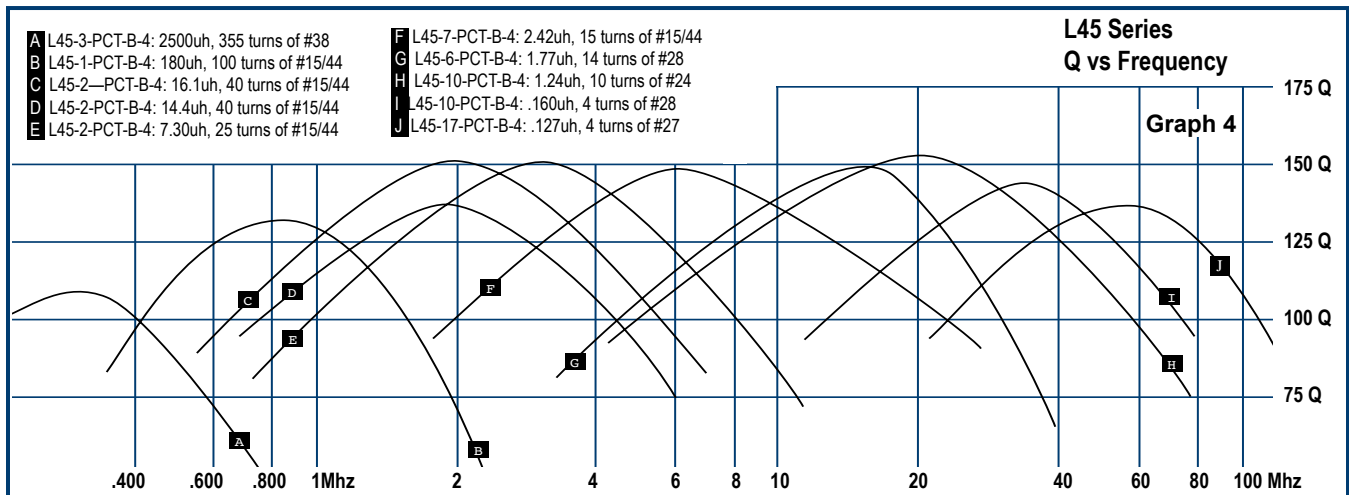
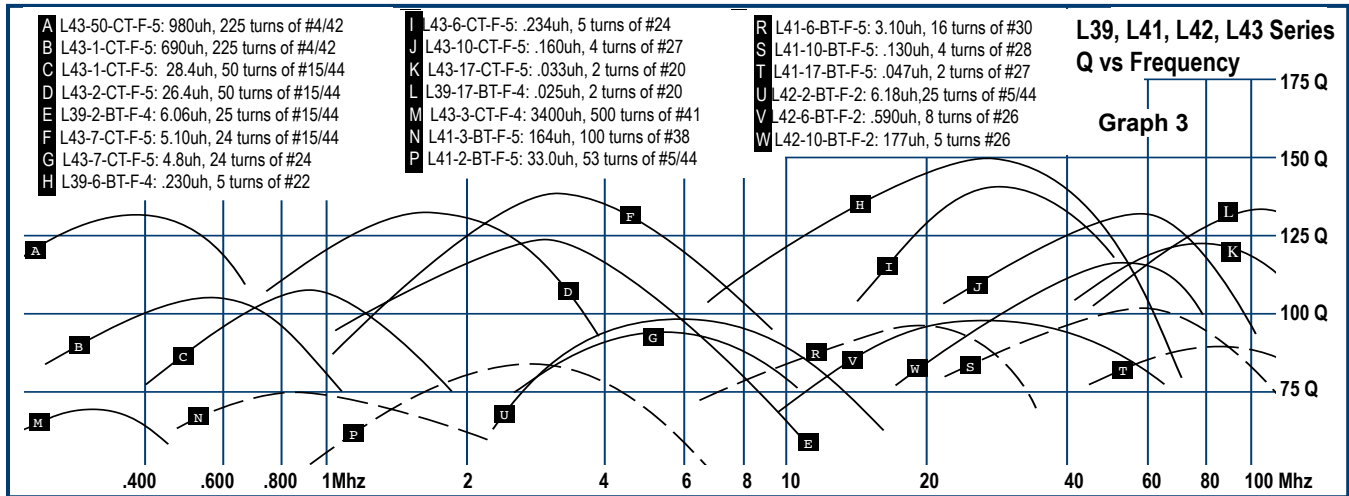

WINDING AFFECTS ON Q

The type and size of the wire used in the winding is also frequency sensitive. This is due to the losses that result in the electronic and magnetic fields emitted from the wire in the winding. As frequency is increased from 100 Khz to 1Mhz, the resistive eddie-current losses increase and the "skin effect" becomes significant. It is possible to minimize the "skin effect" by dividing the conductor into a bundle of interwoven insulated strands called Litzendraht or Litz wire. Depending on the frequency, the strand diameter is chosen so that the skin effect in the individual strands is negligible.

Litz wire is described as 7/41 (7 strands of 41 AWG), or 15/44 (15 strands of 44 AWG.) and will tend towards larger bundles of smaller strands as frequency is increased. Above 1 Mhz, the advantages of reduced resistance using Litz wire are nullified by the disadvantages of increased capacitive losses created by the stranding.

As the capacitance of adjacent turns as well as the capacitance from the winding to the core becomes significant, stranded wire should be abandoned in favor of solid wire. Thus higher frequency windings will tend towards fewer well spaced turns of larger diameter enamel coated magnetic wire.

The positive influence of Litz wire is demonstrated in the L43 series Q curves on Graph 3. With the same number of turns and inductance, the L43-7-CT-F-5 (Curve F) with Litz wire has superior Q to the L43-7-CT-F-5 (Curve G) wound with solid wire at approximately 4 Mhz. It is also evident that L57-2-PCT-B-4 with 50 turns of 15/44 (Curve D) is a more efficient Litz winding than 50 turns of 7/41 on the L57-2-PCT-B-4 (Curve E) tuned to 30µh at 1.5 Mhz. As the capacitive effects begin to dominate the Litz wire becomes a liability. The exact frequency is dependent on the application but the practical transition is from 1 to 10 Mhz.

The winding table below shows the number of turns of Litz and magnetic wire of different gauges that will fit in each of the Shielded Coil Form's winding area. These turns estimates are for indication only. The actual maximum number of turns will depend on insulation thickness and the winding technique.

TEMPERATURE STABILITY

An important characteristic of iron powder core materials is the outstanding temperature stability. The temperature stability information for each material is listed in parts-per-million-per degree Celsius (ppm/°C). As an example, the inductance of a 100ppm/°C material will change by 1% over a temperature change of 100 °C. Figures 4 and 5 plot the temperature stability for iron powder materials as a percentage change in inductance and Q.

The iron powder core materials have excellent temperature stability from -65°C (-150°F) up to 125°C (257°F). Ferrite materials are more sensitive to temperature and will exhibit changes in inductance and Q from 5 to 10 times greater than iron powder over the same temperature range.

In an iron powder core, inductance will increase gradually as the core materials move from 25°C to over 100°C. With continuous operation above 100°C, inductance and Q will begin to degrade with time. The extent of these changes are dependent on time, temperature, and frequency. Iron powder cores tolerate temperatures down to -65°C with no permanent effects.

Extended periods of elevated temperature will result in a permanent shift in inductance and Q when the assembly is returned to ambient. For temperature sensitive applications up to 100°C, this shift can be stabilized by "aging" the core material at 100°C for a minimum of 48 hours.

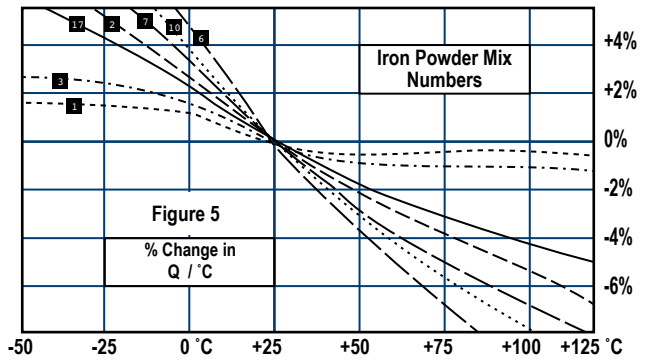
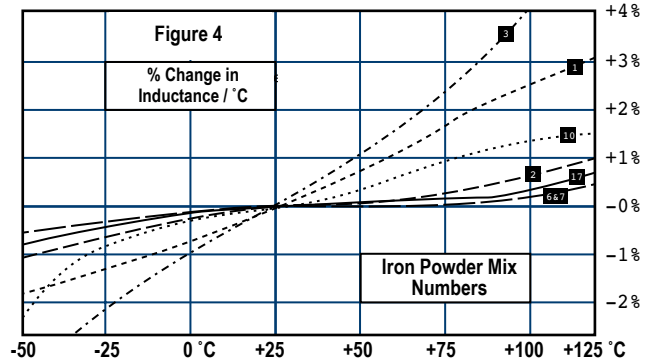

These graphs show relative stability for the core materials alone and should be used only as an indication of the temperature stability of the wound assembly.

SHIELDED COIL FORM WINDING TABLE

WIRE SIZE AWG	20		22		24		26		28		30		32		34		36		38		40		42		
WIRE SIZE LITZ	100/43		60/43		40/43		10/40		10/42		15/45		9/45		6/45		5/47		4/48						
Single Layer	Full Winding		S	F	S	F	S	F	S	F	S	F	S	F	S	F	S	F	S	F	S	F	S	F	
L20												4	4	4	8	4	8	4	32	4	32	4	40	4	112
L28								2	6	4	8	5	15	7	21	9	36	11	66	14	98	18	180	23	270
L30									5	10		5	10	5	20	5	40	5	60	5	120	5	200	5	300
L32								8	15	10	19	13	25	16	58	21	78	27	147	34	244	43	385	55	594
L33								5	5	5	10	5	10	5	20	5	40	5	60	5	120	5	200	5	300
L333/L335								8	15	10	19	13	25	17	62	22	82	27	147	34	244	45	400	55	606
L337								8	15	10	19	13	25	16	58	21	78	27	147	34	244	43	385	55	594
L38								5	25	6	42	8	70	10	110	13	180	16	280	20	440	26	750	31	1100
L40												4	24	4	28	4	36	4	48	4	55	4	72	4	96
L41								4	8	4	8	4	16	4	16	4	24	4	32	4	40	4	55	4	64
L42	4	4	5	9	7	22	9	30	12	57	15	75	19	124	24	222	30	345	38	531	50	924	62	1425	
L43	4	8	6	12	8	16	10	20	13	52	17	102	21	126	27	216	34	404	42	588	55	990	69	1656	
L45	5	8	6	12	8	15	10	19	13	25	17	62	21	78	27	147	34	244	43	385	55	679	70	1107	
L48							4	20	6	42	7	63	9	110	12	165	15	270	19	418	25	725	31	1100	
L57	5	10	6	24	8	32	10	60	13	104	17	170	21	252	27	432	34	680	43	1032	55	1760	70	2800	

5mm Toko 5K, 5KM, 5KR, 5KG Size

Inches/[mm]
±.010/[±.25]
2 x size

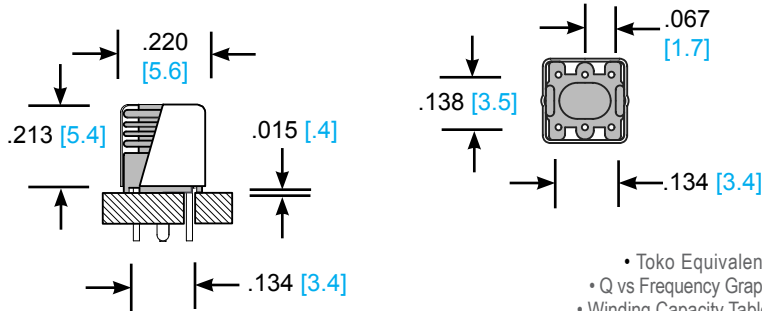

L20 SERIES

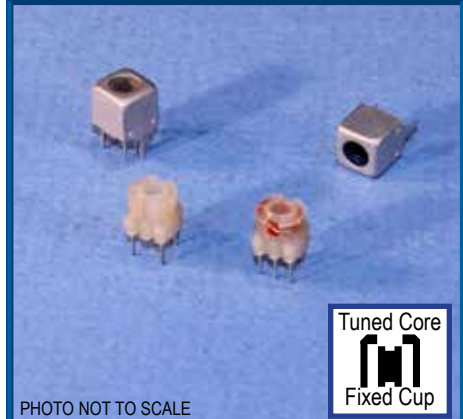

- Toko Equivalent Hardware
- Q vs Frequency Graph on Page 5
- Winding Capacity Table on Page 6
- Ferrite Tuning Core, No Fixed Cup
- Quality Inspection Level: MIL-STD-1916 Level IV
- Available as: Un-wound Hardware or Complete Wound Coils

ASSEMBLY PART NO.	COLOR CODE	MAGNETIC MATERIAL(1)	FREQUENCY RANGE(2)	MATERIAL PERMEABILITY	ASSEMBLY AL nH/turns ² (3)	MAX μh 100 turns	MIN μh (4) 100 turns	TEMPERATURE STABILITY(5)
L20-53-BT-D-5	None	FERRITE 51	.05-2.0 MHz	300	.41	41	28	1500 ppm/°C
L20-54-BT-D-5	None	FARRITE 52	2-150 MHz	60	.42	42	30	1500 ppm/°C

- The ferrite materials are used in the tuning core. This series does not offer a cup core.
- This represents the frequency range for Q optimization in tuned or resonant circuits. The inductive properties of the material is effective over a considerably wider frequency range.
- Nanohenries (10⁻⁹ Henries) per turn squared.
- The minimum inductance is measured in microhenries (10⁻⁶ Henries) per 100 turns with the tuning core tuned out of the winding area but still a part of the assembly.
- The temperature stability is of the magnetic material, measured in parts per million per degree Celsius (ppm/°C) on a toroidal core and winding. This is only an indication of the temperature stability for a complete wound assembly.

Custom Wound Variable Coils

Example Part Number

Test Frequencies (Mhz): 25.2 (0.1 to 1μh), 7.96 (1μh to 10μh), 2.52 (10 to 100μh), .796 (100μh to 1mh), .252 (1mh to 10mh)

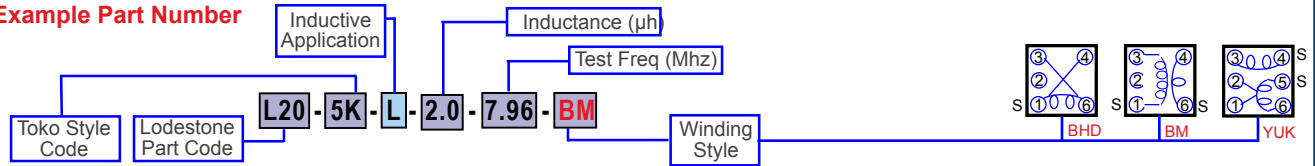

5mm

Toko 5K, 5KM, 5KR, 5KG Size

Custom Variable Coils are wound to your Inductance and Frequency Specifications. There is no room for an internal capacity in the L20 Series.

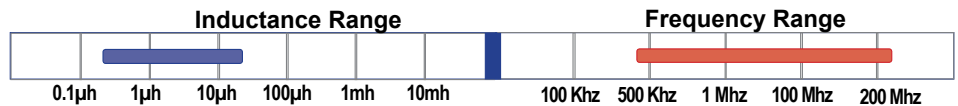

Assembly Sub-components

Actual Size

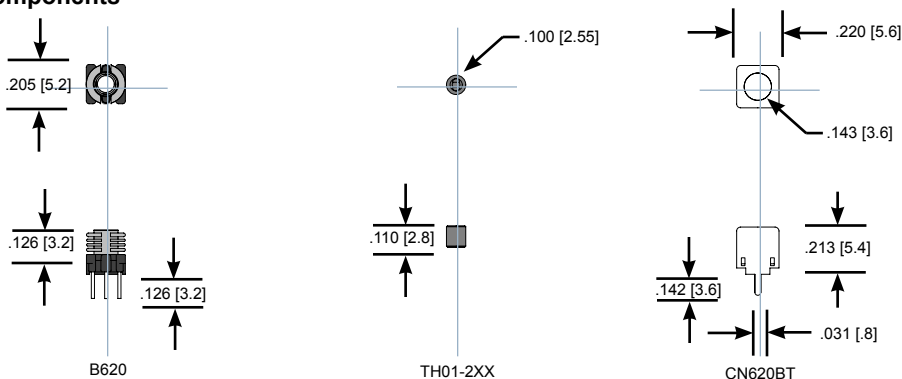

Inches/[mm]
±.010/[±.25]

5 TERMINAL ASSEMBLY	BASE and COILFORM	COLOR CODE	TUNING CORE (8)	SHIELD CAN
L20-52-BT-D-5	B620	None	TH01-253	CN480BT
L20-53-BT-D-5	B620	None	TH01-254	CN480BT

- The base and coil form are one piece molded in Polymethylpentene (PMP). The 5 terminals are brass, .016 inches (0.4mm) in diameter, 100% tin plated to meet MIL-STD 202 method 208 for solderability.
- The base does not have space for an internal capacitor.
- A ferrite shield cup is not part of this assembly.

L28 SERIES

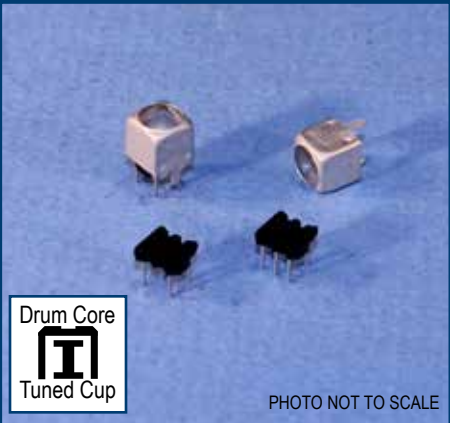

Drum Core Tuned Cup

PHOTO NOT TO SCALE

Toko 5P, 5PG, 5PAG Size 5mm

Inches/[mm]
±.010/[±.25]
2 x size

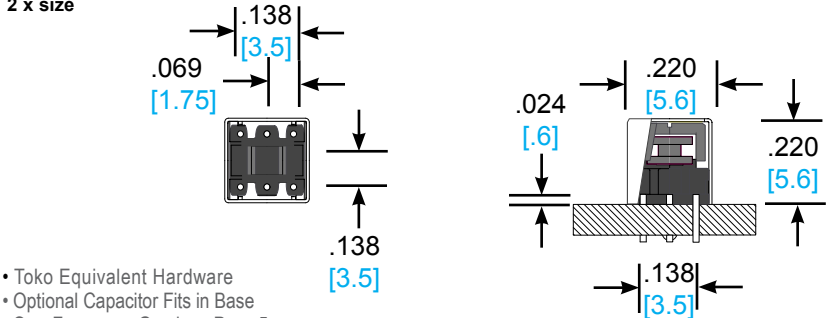

- Toko Equivalent Hardware
- Optional Capacitor Fits in Base
- Q vs Frequency Graph on Page 5
- Winding Capacity Table on Page 6
- Ferrite Tuning Core and Fixed Cup
- Quality Inspection Level: MIL-STD-1916 Level IV
- Available as: Un-wound Hardware or Complete Wound Coils



ASSEMBLY PART NO.	COLOR CODE	MAGNETIC MATERIAL(1)	FREQUENCY RANGE(2)	MATERIAL PERMEABILITY	ASSEMBLY AL nH/turns ² (3)	MAX µH 100 turns	MIN µH (4) 100 turns	TEMPERATURE STABILITY(5)
L28-51-BT-D-5	None	FERRITE 51	.05-2.0 MHz	300	25.7	257	129	1500 ppm/°C
L28-52-BT-D-5	None	FARRITE 52	2-200 MHz	60	24.8	248	124	1500 ppm/°C

1) The ferrite materials are used in the drum core and cup core.
 2) This represents the frequency range for Q optimization in tuned or resonant circuits. The inductive properties of the material is effective over a considerably wider frequency range.
 3) Nanohenries (10⁻⁹ Henries) per turn squared.
 4) The minimum inductance is measured in microhenries (10⁻⁶ Henries) per 100 turns with the tuning core tuned out of the winding area but still a part of the assembly.
 5) The temperature stability is of the magnetic material, measured in parts per million per degree Celsius (ppm/°C) on a toroidal core and winding. This is only an indication of the temperature stability for a complete wound assembly.

Custom Wound Variable Coils

Example Part Number

Tokos Style Code

Lodestone Part Code

L28 - 5P - L - 2.0 - 7.96 - BM

L28 - 5P - C - 22 - 10.7 - A

Inductive Application

Inductance (µH)

Test Freq (Mhz)

Winding Style

Self Resonant Freq (Mhz)

Capacitive Application

Capacitance (pf)

Test Frequencies (Mhz): 25.2 (0.1 to 1µH), 7.96 (1µH to 10µH), 2.52 (10 to 100µH), .796 (100µH to 1mH), .252 (1mH to 10mH)

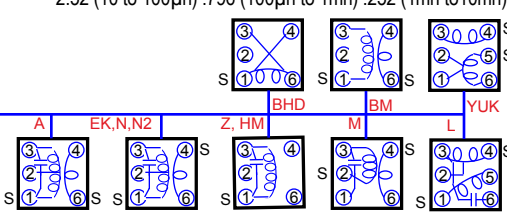

Internal Capacitors (pf): Selected to meet the specified self-resonant frequency

Inductance Range

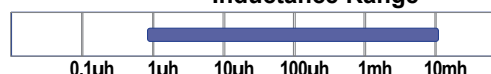

Frequency Range

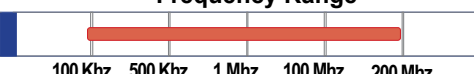

Custom Variable Coils are wound to your Inductance and Frequency Specifications, or with Capacitors to your Self-resonant Frequency Specifications.

Assembly Sub-components

Actual Size

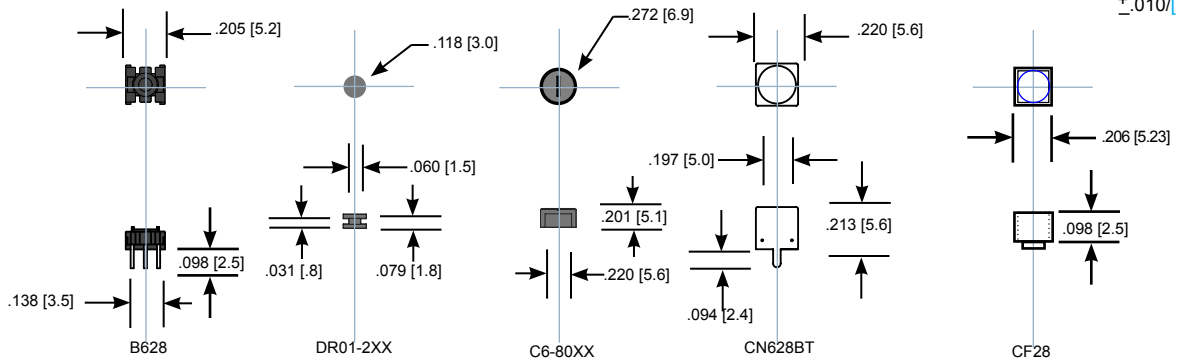

Inches/[mm]
±.010/[±.25]

5 TERMINAL ASSEMBLY	BASE with DRUM CORE (6)	COLOR CODE	DRUM CORE (8)	CUP CORE	SHIELD CAN	CAN FORM
L48-51-BT-D-5	B628	None	DR01-251	C6-8051	CN628BT	CF28
L48-52-BT-D-5	B628	None	DR01-252	C6-8052	CN628BT	CF28

6) The base is molded in a phenolic thermoset. The 5 terminals are brass, .027 inches (0.7mm) in diameter, 100 % tin plated to meet MIL-STD 202 method 208 for solderability.
 7) The ferrite drum core is attached to the thermoset base.
 8) Threaded cup matches the internal threads in the Cup Form. 9) The base has a cavity for an optional capacitor .185 [4.7] Long x .087 [2.2] Wide x .079 [2.0] Deep. Capacitors are not included.

7mm Toko 7KL, 7KLL Size, Short version of 7KM, 7KMM Inches/[mm] $\pm .010/(\pm .25)$ 2 x size

L30 SERIES

Tuned Core
Fixed Cup

PHOTO NOT TO SCALE

- Toko Equivalent Hardware
- Optional Capacitor Fits in Base
- Q vs Frequency Graph on Page 5
- Winding Capacity Table on Page 6
- Ferrite Tuning Core and Fixed Cup
- Quality Inspection Level: MIL-STD-1916 Level IV
- Available as: Un-wound Hardware or Complete Wound Coils

ASSEMBLY PART NO. (Un-Wound)	COLOR CODE	MAGNETIC MATERIAL(1)	FREQUENCY RANGE(2)	MATERIAL PERMEABILITY	ASSEMBLY AL nH/turns ² (3)	MAX μ H 100 turns	MIN μ H (4) 100 turns	TEMPERATURE STABILITY(5)
L30-53-BT-F-5	None	FERRITE 53	.05-2.0 MHz	44	10.4	104	44	1500 ppm/°C
L30-54-BT-F-5	None	FARRITE 54	2-200 MHz	25	14.8	148	71	1500 ppm/°C

1) The ferrite materials are used in the tuning core and cup core.
 2) This represents the frequency range for Q optimization in tuned or resonant circuits. The inductive properties of the material is effective over a considerably wider frequency range.
 3) Nanohenries (10^{-9} Henries) per turn squared.
 4) The minimum inductance is measured in microhenries (10^{-6} Henries) per 100 turns with the tuning core tuned out of the winding area but still a part of the assembly.
 5) The temperature stability is of the magnetic material, measured in parts per million per degree Celsius (ppm/°C) on a toroidal core and winding. This is only an indication of the temperature stability for a complete wound assembly.

Custom Wound Variable Coils

Example Part Number

Toko Style Code: L30-7KL-L-2.0-7.96-BM
 Lodestone Part Code: L30-7KL-C-22-10.7-A

Inductive Application: Inductance (μ H), Test Freq (MHz)
 Capacitive Application: Self Resonant Freq (MHz), Capacitance (pF)

Winding Style: A, EK,N,N2, Z, HM, BHD, M, L, YUK

Internal Capacitors (pF): Selected to meet the specified self-resonant frequency

7mm

Toko 7KL, 7KLL Size, Short version of 7KM, 7KMM

Custom Variable Coils are wound to your Inductance and Frequency Specifications, or with Capacitors to your Self-resonant Frequency Specifications.

Assembly Sub-components

Actual Size

5 TERMINAL ASSEMBLY	BASE with COIL FORM (6)	COLOR CODE	THREADED CORE (8)	CUP CORE	SHIELD CAN
L30-53-BT-F-5	B630	None	TH13-53	C9-4053	CN6300BT
L30-54-BT-F-5	B630	None	TH13-54	C9-4054	CN6300BT

(6) *The base and coil form are one piece molded in Polymethylpentene (PMP). The 5 terminals are brass, .02 inches (0.5mm) in diameter, 100% tin plated to meet MIL-STD 202 method 208 for solderability.
 (7) The ferrite tuning cores is 3.3mm metric, shallow thread.
 (8) The base has a cavity for an optional capacitor. .236 [6mm] Long x .08 [2.1mm] Wide x .08 [2.1mm] Deep. Capacitors are not included.

L32 SERIES



Tuned Core
Fixed Cup

PHOTO NOT TO SCALE

Inches/[mm]
±.010/[±.25]
2 x size

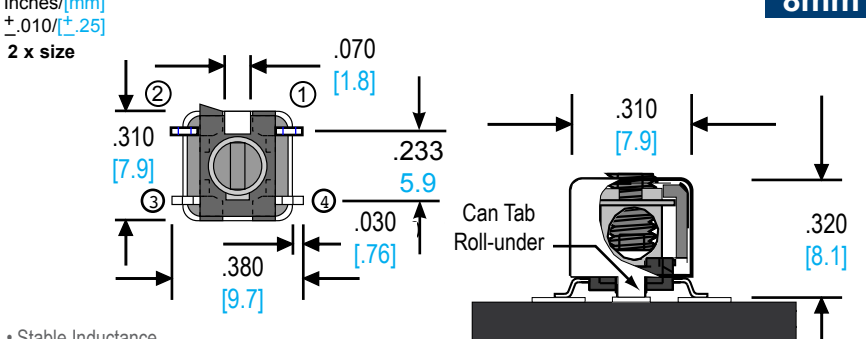

- Stable Inductance
- Superior Temperature Stability
- Q vs Frequency Graph on Page 5
- Winding Capacity Table on Page 6
- Available as: Un-wound Hardware Only
- Quality Inspection Level: MIL-STD-1916 Level IV



ASSEMBLY PART NO.	COLOR CODE	MAGNETIC MATERIAL(1)	FREQUENCY RANGE (2)	MATERIAL PERMEABILITY	ASSEMBLY AL nH/turns ² (3)	MAX µh 100 turns	MIN µh (4) 100 turns	TEMPERATURE STABILITY(5)
L32-2-CT-F-2	RED	CARBONYL E	.25-10 MHZ	10.0	6.8	68	45	95 ppm/°C
L32-3-CT-F-2	GREY	CARBONYL HP	.02-1.0 MHZ	35.0	7.8	78	46	370 ppm/°C
L32-6-CT-F-2	YELLOW	CARBONYL SF	2.0-50 MHZ	8.5	6.1	61	38	35 ppm/°C
L32-10-CT-F-2	BLACK	CARBONYL W	10-100 MHZ	6.0	5.7	57	37	150 ppm/°C
L32-17-CT-F-2	LAVENDER	CARBONYL	20-200 MHZ	4.0	5.2	52	37	50 ppm/°C

1) The iron powder or ferrite materials are used in a portion of the base, the tuning core and cup core.
 2) This represents the frequency range for Q optimization in tuned or resonant circuits. The inductive properties of the material is effective over a considerably wider frequency range.
 3) Nanohenries (10⁹ Henries) per turn squared.
 4) The minimum inductance is measured in microhenries (10⁶ Henries) per 100 turns with the tuning core tuned out of the winding area but still a part of the assembly.
 5) The temperature stability is of the magnetic material, measured in parts per million per degree Celsius (ppm/°C) on a toroidal core and winding. This is only an indication of the temperature

Assembly Sub-components

Actual Size

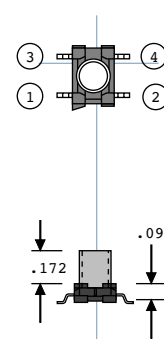

B534-w/CF132

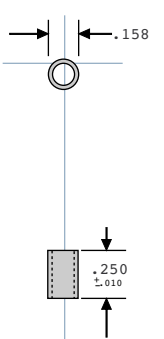

CF132

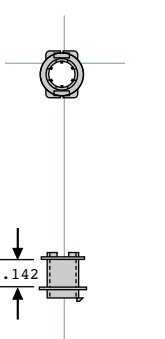

PB132

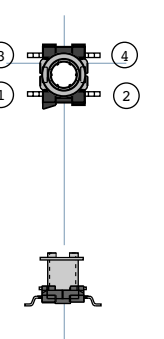

B534-w/PB132

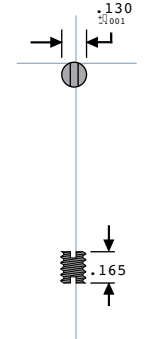

TH12-3 ()

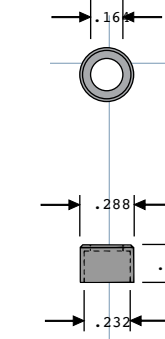

C9-33 ()

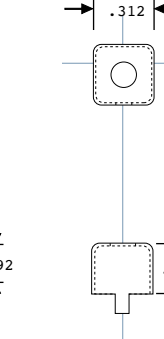

CN432CT

4 TERMINAL ASSEMBLY (6)	COIL FORM BASE ASSEMBLY (7)	BASE ONLY	BOBBIN WINDING FORM (8)	BOBBIN BASE ASSEMBLY	COLOR CODE	THREADED CORE (9)	CUP CORE	SHIELD CAN
L32-2-CT-F-4	B532-w/CF132	B532	PB132	B532-w/PB132	RED	TH12-302	C9-3302	CN432CT
L32-3-CT-F-4	B532-w/CF132	B532	PB132	B532-w/PB132	GREY	TH12-303	C9-3303	CN432CT
L32-6-CT-F-4	B532-w/CF132	B532	PB132	B532-w/PB132	YELLOW	TH12-306	C9-3306	CN432CT
L32-10-CT-F-4	B532-w/CF132	B532	PB132	B532-w/PB132	BLACK	TH12-310	C9-3310	CN432CT
L32-17-CT-F-4	B532-w/CF132	B532	PB132	B532-w/PB132	LAVENDER	TH12-317	C9-3317	CN432CT

6) Coplanarity of the two terminal version is not an issue due to three contact points. The four terminal version's coplanarity will depend on the success of the can tab's (fifth) contact point.
 7) The base is molded in theroset Diallyl Phthalate (DAP). Two terminal (positions 3 & 4) and four terminal (positions 1,2 3 & 4) are available in Alloy 42, 90/10 tin plated to MIL-STD 202, 208 for solderability. The CF117 coilform is a glass reinforced polyester tube with 8-32 internal threads.
 8) The optional PB132 snap in bobbin is self threading polypropylene. To order, substitute "P" for "F" in the assembly part number.
 9) The tuning core is a 6-32 shallow thread coated with Teflon.
 10) The tab on the shield can bends under the base, holding the shield can in place and creating the surface mount connection to the circuit board.

8mm

Inches/[mm]
±.010/
2 x size

L33 SERIES

Tuned Core
Fixed Cup

PHOTO NOT TO SCALE

- Stable Inductance
- Superior Temperature Stability
- Q vs Frequency Graph on Page 5
- Winding Capacity Table on Page 6
- Available as: Un-wound Hardware Only
- Quality Inspection Level: MIL-STD-1916 Level IV

ASSEMBLY PART NO.	COLOR CODE	MAGNETIC MATERIAL (1)	FREQUENCY RANGE (2)	MATERIAL PERMEABILITY	ASSEMBLY AL nH/turn ² (3)	MAX μH 100 turns	MIN μH (4) 100 turns	TEMPERATURE STABILITY (5)
L33-1-CT-F-4	BLUE	CARBONYL C	.15-2.0 MHZ	20.0	7.6	76	45	280 ppm/°C
L33-2-CT-F-4	RED	CARBONYL E	.25-10 MHZ	10.0	6.8	68	45	95 ppm/°C
L33-3-CT-F-4	GREY	CARBONYL HP	.02-1.0 MHZ	35.0	8.0	80	46	370 ppm/°C
L33-6-CT-F-4	YELLOW	CARBONYL SF	2.0-50 MHZ	8.5	6.0	60	38	35 ppm/°C
L33-7-CT-F-4	WHITE	CARBONYL TH	1.0-20 MHZ	9.0	6.4	64	40	30 ppm/°C
L33-10-CT-F-4	BLACK	CARBONYL W	10-100MHZ	6.0	5.4	54	37	150 ppm/°C
L33-17-CT-F-4	LAVENDER	CARBONYL	20-200MHZ	4.0	4.8	48	37	50 ppm/°C

1) The iron powder or ferrite materials are used in the tuning core and cup core.
 2) This represents the frequency range for Q optimization in tuned or resonant circuits. The inductive properties of the material is effective over a considerably wider frequency range.
 3) Nanohenries (10⁻⁹ Henries) per turn squared.
 4) The minimum inductance is measured in microhenries (10⁻⁶ Henries) per 100 turns with the tuning core tuned out of the winding area but still a part of the assembly.
 5) The temperature stability is of the magnetic material, measured in parts per million per degree Celsius (ppm/°C) on a toroidal core and winding. This is only an indication of the temperature stability for a complete wound assembly.

Assembly Sub-components

Actual Size

B514-w/CF113

CF113

TH13-1()

C9-30()

CN401CT

Inches/[mm]
±.010/[±.25]

4 TERMINAL ASSEMBLY	BASE ONLY (6)	WINDING FORM (7)	BASE ASSEMBLY	COLOR CODE	THREADED CORE (8)	CUP CORE	SHIELD CAN
L33-1-CT-F-4	B514	CF113	B514-w/CF113	BLUE	TH13-101	C9-3001	CN401CT
L33-2-CT-F-4	B514	CF113	B514-w/CF113	RED	TH13-102	C9-3002	CN401CT
L33-3-CT-F-4	B514	CF113	B514-w/CF113	GREY	TH13-103	C9-3003	CN401CT
L33-6-CT-F-4	B514	CF113	B514-w/CF113	YELLOW	TH13-106	C9-3006	CN401CT
L33-7-CT-F-4	B514	CF113	B514-w/CF113	WHITE	TH13-107	C9-3007	CN401CT
L33-10-CT-F-4	B514	CF113	B514-w/CF113	BLACK	TH13-110	C9-3010	CN401CT
L33-17-CT-F-4	B514	CF113	B514-w/CF113	LAVENDER	TH13-117	C9-3017	CN401CT

5 TERMINAL ASSEMBLY							
L33-()-CT-F-5	B515	CF113	B515-w/CF113	AS ABOVE	TH13-1()	C9-30()	CN401CT

6) The base is moulded from thermoset Diallyl Phthalate (DAP). The 4 or 5 terminals available are half hard brass .024 inches in diameter, tin plated to MIL-STD 202 Method 208 for solderability. Optional base B524 is available with .050 standoffs.
 7) The coil form is a glass reinforced polyester tube with 6-32 internal threads.
 8) The tuning core is 6-32 shallow thread coated with Teflon.

L335 SERIES

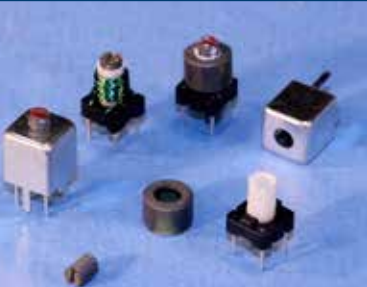

Tuned Core
Fixed Cup

PHOTO NOT TO SCALE

8mm

Inches/[mm]
±.010/[±.25]
2 x size

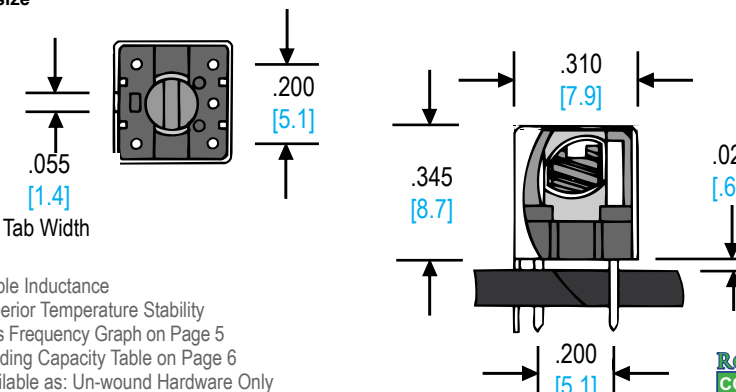

- Stable Inductance
- Superior Temperature Stability
- Q vs Frequency Graph on Page 5
- Winding Capacity Table on Page 6
- Available as: Un-wound Hardware Only
- Quality Inspection Level: MIL-STD-1916 Level IV



ASSEMBLY PART NO.	COLOR CODE	MAGNETIC MATERIAL (1)	FREQUENCY RANGE (2)	MATERIAL PERMEABILITY	ASSEMBLY AL nH/turns ² (3)	MAX μH 100 turns	MIN μH (4) 100 turns	TEMPERATURE STABILITY (5)
L335-1-CT-F-4	BLUE	CARBONYL C	.15-2.0 MHz	20.0	7.4	74	45	280 ppm/°C
L335-2-CT-F-4	RED	CARBONYL E	.25-10 MHz	10.0	6.8	68	45	95 ppm/°C
L335-3-CT-F-4	GREY	CARBONYL HP	.02-1.0 MHz	35.0	7.8	78	46	370 ppm/°C
L335-6-CT-F-4	YELLOW	CARBONYL SF	2.0-50 MHz	8.5	6.1	61	38	35 ppm/°C
L335-7-CT-F-4	WHITE	CARBONYL TH	1.0-20 MHz	9.0	6.4	64	40	30 ppm/°C
L335-10-CT-F-4	BLACK	CARBONYL W	10-100 MHz	6.0	5.7	57	37	150 ppm/°C
L335-17-CT-F-4	LAVENDER	CARBONYL	20-200 MHz	4.0	5.2	52	37	50 ppm/°C

1) The iron powder materials are used in the tuning core and cup core.
 2) This represents the frequency range for Q optimization in tuned or resonant circuits. The inductive properties of the material is effective over a considerably wider frequency range.
 3) Nanohenries (10⁻⁹ Henries) per turn squared.
 4) The minimum inductance is measured in microhenries (10⁻⁶ Henries) per 100 turns with the tuning core tuned out of the winding area but still a part of the assembly.
 5) The temperature stability is of the magnetic material, measured in parts per million per degree Celsius (ppm/°C) on a toroidal core and winding. This is only an indication of the temperature stability for a complete wound assembly.

Assembly Sub-components

Actual Size

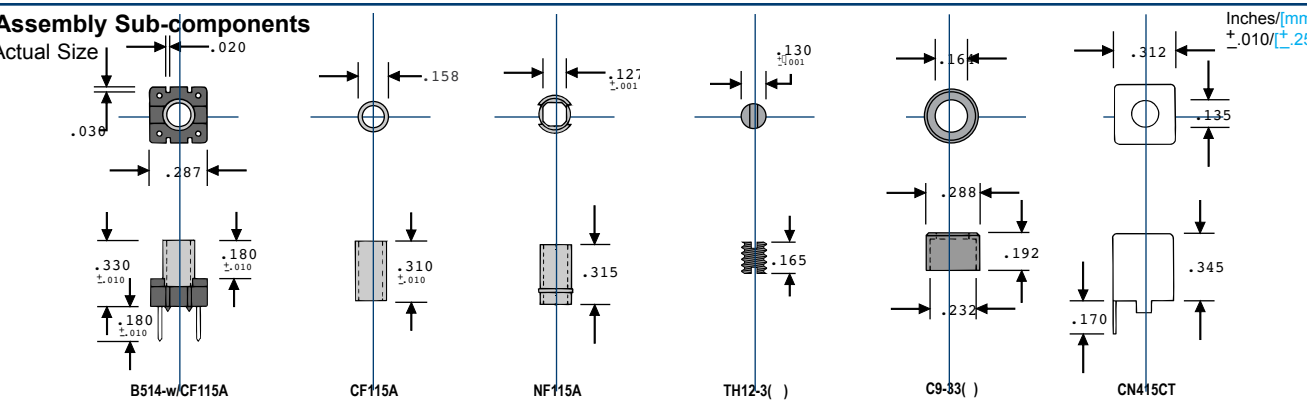

4 TERMINAL ASSEMBLY	BASE ONLY (6)	WINDING FORM (7)	BASE ASSEMBLY	COLOR CODE	THREADED CORE (8)	CUP CORE	SHIELD CAN
L335-1-CT-F-4	B514	CF115A	B514-w/CF115A	BLUE	TH12-301	C9-3301	CN415CT
L335-2-CT-F-4	B514	CF115A	B514-w/CF115A	RED	TH12-302	C9-3302	CN415CT
L335-3-CT-F-4	B514	CF115A	B514-w/CF115A	GREY	TH12-303	C9-3303	CN415CT
L335-6-CT-F-4	B514	CF115A	B514-w/CF115A	YELLOW	TH12-306	C9-3306	CN415CT
L335-7-CT-F-4	B514	CF115A	B514-w/CF115A	WHITE	TH12-307	C9-3307	CN415CT
L335-10-CT-F-4	B514	CF115A	B514-w/CF115A	BLACK	TH12-310	C9-3310	CN415CT
L335-17-CT-F-4	B514	CF115A	B514-w/CF115A	LAVENDER	TH12-317	C9-3317	CN415CT
5 TERMINAL ASSEMBLY							
L335(-)CT-F-5	B515	CF115A	B515-w/CF115A	AS ABOVE	TH12-3()	C9-33()	CN415CT
L335 WITH NYLON COILFORM AND 4 OR 5 TERMINALS							
L335(-)CT-NF-4	B514	NF115A	B514-w/NF115A	AS ABOVE	TH12-3()	C9-33()	CN415CT
L335(-)CT-NF-5	B515	NF115A	B515-w/NF115A	AS ABOVE	TH12-3()	C9-33()	CN415CT

6) The base is moulded from theroset Diallyl Phthalate (DAP). The 4 or 5 terminals available are half hard brass, .024 inches in diameter, tin plated to MIL-STD 202 Method 208 for solderability. Optional base B524 is available with .050 standoffs.
 7) The CF115A coil form is a glass reinforced polyester tube with 6-32 internal threads. The NF coil form is self threading nylon 6/6.
 8) The tuning core is 6-32 shallow thread coated with Teflon.

8mm

Inches/[mm]
±.010/[±.25]
2 x size

Tab Width

L337 SERIES

Tuned Core
Fixed Cup

PHOTO NOT TO SCALE

- Stable Inductance
- Superior Temperature Stability
- Q vs Frequency Graph on Page 5
- Winding Capacity Table on Page 6
- Available as: Un-wound Hardware Only
- Quality Inspection Level: MIL-STD-1916 Level IV

ASSEMBLY PART NO.	COLOR CODE	MAGNETIC MATERIAL(1)	FREQUENCY RANGE (2)	MATERIAL PERMEABILITY	ASSEMBLY AL nH/turn ² (3)	MAX μH 100 turns	MIN μH (4) 100 turns	TEMPERATURE STABILITY(5)
L337-1-CT-F-4	BLUE	CARBONYL C	.15-2.0 MHZ	20.0	7.6	76	45	280 ppm/°C
L337-2-CT-F-4	RED	CARBONYL E	.25-10 MHZ	10.0	6.8	68	45	95 ppm/°C
L337-3-CT-F-4	GREY	CARBONYL HP	.02-1.0 MHZ	35.0	8.0	80	46	370 ppm/°C
L337-6-CT-F-4	YELLOW	CARBONYL SF	2.0-50 MHZ	8.5	6.0	60	38	35 ppm/°C
L337-7-CT-F-4	WHITE	CARBONYL TH	1.0-20 MHZ	9.0	6.4	64	40	30 ppm/°C
L337-10-CT-F-4	BLACK	CARBONYL W	10-100MHZ	6.0	5.4	54	37	150 ppm/°C
L337-17-CT-F-4	LAVENDER	CARBONYL	20-200MHZ	4.0	4.8	48	37	50 ppm/°C

1) The iron powder or ferrite materials are used in the tuning core and cup core.
 2) This represents the frequency range for Q optimization in tuned or resonant circuits. The inductive properties of the material is effective over a considerably wider frequency range.
 3) Nanohenries (10⁻⁹ Henries) per turn squared.
 4) The minimum inductance is measured in microhenries (10⁻⁶ Henries) per 100 turns with the tuning core tuned out of the winding area but still a part of the assembly.
 5) The temperature stability is of the magnetic material, measured in parts per million per degree Celsius (ppm/°C) on a toroidal core and winding. This is only an indication of the temperature stability for a complete wound assembly.

Assembly Sub-components

Actual Size

B514-w/CF117

CF117

TH12-1()

C9-37()

CN417CT

4 TERMINAL ASSEMBLY	BASE ONLY (6)	WINDING FORM (7)	BASE ASSEMBLY	COLOR CODE	THREADED CORE (8)	CUP CORE	SHIELD CAN
L337-1-CT-F-4	B514	CF117	B514-w/CF117	BLUE	TH12-101	C9-3701	CN417CT
L337-2-CT-F-4	B514	CF117	B514-w/CF117	RED	TH12-102	C9-3702	CN417CT
L337-3-CT-F-4	B514	CF117	B514-w/CF117	GREY	TH12-103	C9-3703	CN417CT
L337-6-CT-F-4	B514	CF117	B514-w/CF117	GREY/ORANGE	TH12-106	C9-3706	CN417CT
L337-7-CT-F-4	B514	CF117	B514-w/CF117	YELLOW	TH12-107	C9-3707	CN417CT
L337-10-CT-F-4	B514	CF117	B514-w/CF117	WHITE	TH12-110	C9-3710	CN417CT
L337-17-CT-F-4	B514	CF117	B514-w/CF117	BLACK	TH12-117	C9-3717	CN417CT

5 TERMINAL ASSEMBLY

L337-()-CT-F-5	B515	CF117	B515-w/CF117	AS ABOVE	TH12-1()	C9-37()	CN417CT
-----------------	------	-------	--------------	----------	-----------	----------	---------

6) The base is moulded from thermoset Diallyl Phthalate (DAP). The 4 or 5 terminals available are half hard brass, .024 inches in diameter, tin plated to MIL-STD 202 Method 208 for solderability. Optional base B524 is available with .050 standoffs.
 7) The coil form is a glass reinforced polyester tube with 6-32 internal threads.
 8) The tuning core is 6-32 shallow thread coated with Teflon.

L38 SERIES

PHOTO NOT TO SCALE

Toko 7P 7PA, 7PL, PLA Size 7mm

Inches/[mm]
±.010/[±.25]
2 x size

Dimensions: .088 [2.3], .177 [4.5], .280 [7.1], .295 [7.5], .03 [.7], .445 [11.3], .177 [4.5]

- Toko Equivalent Hardware
- Optional Capacitor Fits in Base
- Q vs Frequency Graph on Page 5
- Winding Capacity Table on Page 6
- Ferrite Drum Core and Tuning Cup
- Available as: Un-wound Hardware or Complete Wound Coils

ASSEMBLY PART NO.	COLOR CODE	MAGNETIC MATERIAL(1)	FREQUENCY RANGE(2)	MATERIAL PERMEABILITY	ASSEMBLY AL. nH/turns ² (3)	MAX µh 100 turns	MIN µh (4) 100 turns	TEMPERATURE STABILITY(5)
L38-51-BT-D-5	None	FERRITE 51	.05-2.0 MHz	300	46.3	463	200	1500 ppm/°C
L38-52-BT-D-5	None	FARRITE 52	2-200 MHz	60	32.0	320	164	1500 ppm/°C

1) The ferrite materials are used in the tuning cup and drum core.
 2) This represents the frequency range for Q optimization in tuned or resonant circuits. The inductive properties of the material is effective over a considerably wider frequency range.
 3) Nanohenries (10⁹ Henries) per turn squared.
 4) The minimum inductance is measured in microhenries (10⁶ Henries) per 100 turns with the tuning core tuned out of the winding area but still a part of the assembly.
 5) The temperature stability is of the magnetic material, measured in parts per million per degree Celsius (ppm/°C) on a toroidal core and winding. This is only an indication of the temperature stability for a complete wound assembly.

Custom Wound Variable Coils

Example Part Number

Toko Style Code: L38-7PA-L-2.0-7.96-BM

Lodestone Part Code: L38-7PA-C-22-10.7-A

Inductive Application

Inductance (µh): 2.0, 7.96

Test Freq (Mhz): 7.96

Winding Style: BM

Capacitive Application

Capacitance (pf): 22, 10.7

Self Resonant Freq (Mhz): 10.7

Winding Style: A

Test Frequencies (Mhz): 25.2 (0.1 to 1µh), 7.96 (1µh to 10µh), 2.52 (10 to 100µh), .796 (100µh to 1mh), .252 (1mh to 10mh)

Internal Capacitors (pf): Selected to meet the specified self-resonant frequency

Inductance Range

Frequency Range

Custom Variable Coils are wound to your Inductance and Frequency Specifications, or with Capacitors to your Self-resonant Frequency Specifications. 100 Unit Minimum.

Assembly Sub-components

Actual Size

Inches/[mm]
±.010/[±.25]

5 TERMINAL ASSEMBLY	BASE with DRUM CORE (6)	COLOR CODE	DRUM CORE (8)	CUP CORE	SHIELD CAN
L38-51-BT-D-5	B380	None	DR13-151	C9-8051	CN480BT
L38-52-BT-D-5	B380	None	DR13-152	C9-8052	CN480BT

6) "The base is molded in a phenolic thermoset. The 5 terminals are brass, ".020 inches (0.5mm) in diameter, 100% tin plated to meet MIL-STD 202 method 208 for solderability." 7) The ferrite drum core is attached to the thermoset base.
 8) Threaded cup matches the internal threads in the Cup Form 9) The base has a cavity for an optional capacitor .225 [5.8mm] Long x .095 [2.4mm] Wide x .110 [2.8mm] Deep. Capacitors are not included.

10mm Toko 10K Equivalent

Inches/[mm]
±.010/[±.25]
2 x size

- Toko Equivalent Hardware
- Optional Capacitor Fits in Base
- Q vs Frequency Graph on Page 5
- Winding Capacity Table on Page 6
- Ferrite Tuning Core and Fixed Cup
- Quality Inspection Level: MIL-STD-1916 Level IV
- Available as: Un-wound Hardware or Complete Wound Coils

ROHS COMPLIANT REACH

L40 SERIES

Tuned Core
Fixed Cup

PHOTO NOT TO SCALE

ASSEMBLY PART NO.	COLOR CODE	MAGNETIC MATERIAL(1)	FREQUENCY RANGE(2)	MATERIAL PERMEABILITY	ASSEMBLY AL. nH/turns ² (3)	MAX μH 100 turns	MIN μH (4) 100 turns	TEMPERATURE STABILITY(5)
L40-53-BT-D-5	None	FERRITE 51	.05-20 MHz	44	16.0	160	56	1500 ppm/°C
L40-54-BT-D-5	None	FARRITE 52	2-200 MHz	25	47.0	470	137	1500 ppm/°C

1) The ferrite materials are used in the tuning core and cup core.
 2) This represents the frequency range for Q optimization in tuned or resonant circuits. The inductive properties of the material is effective over a considerably wider frequency range.
 3) Nanohenries (10⁻⁹ Henries) per turn squared.
 4) The minimum inductance is measured in microhenries (10⁻⁶ Henries) per 100 turns with the tuning core tuned out of the winding area but still a part of the assembly.
 5) The temperature stability is of the magnetic material, measured in parts per million per degree Celsius (ppm/°C) on a toroidal core and winding. This is only an indication of the temperature stability for a complete wound assembly.

Custom Wound Variable Coils

Example Part Number

Toko Style Code: L40-10K-L-2.0-7.96-BM
 Lodestone Part Code: L40-10K-C-22-10.7-A

Inductive Application: Inductance (μH), Test Freq (MHz)
 Capacitive Application: Self Resonant Freq (MHz), Capacitance (pF)

Winding Style: A, EK,N,N2, Z, HM, BHD, BM, YUK, M, L

Test Frequencies (Mhz): 25.2 (0.1 to 1μH), 7.96 (1μH to 10μH), 2.52 (10 to 100μH), .796 (100μH to 1mH), .252 (1mH to 10mH)

Internal Capacitors (pF): Selected to meet the specified self-resonant frequency

Inductance Range

Frequency Range

10mm Toko 10K Size

Custom Variable Coils are wound to your Inductance and Frequency Specifications, or with Capacitors to your Self-resonant Frequency Specifications.

Assembly Sub-components

Actual Size

5 TERMINAL ASSEMBLY	BASE with COIL FORM (6)	COLOR CODE	DRUM CORE (8)	CUP CORE	SHIELD CAN
L40-53-BT-D-5	B340	None	TH25-353	C12-6053	CN340BT
L40-54-BT-D-5	B340	None	TH25-354	C12-6054	CN340BT

6) "The base is molded in a phenolic thermoset. The attached coilform is molded in polypropylene. The 5 terminals are brass, .027 inches (0.7mm) in diameter, 100% tin plated to meet MIL-STD 202 method 208 for solderability."
 7) The base has a cavity for an optional capacitor. .225 [5.7mm] Long x .062 [1.6mm] Wide x .107 [2.7mm] Deep. Capacitors are not included.

L41 SERIES



Tuned Core
Fixed Cup

PHOTO NOT TO SCALE

Inches/[mm]
±.010/[±.25]
2 x size

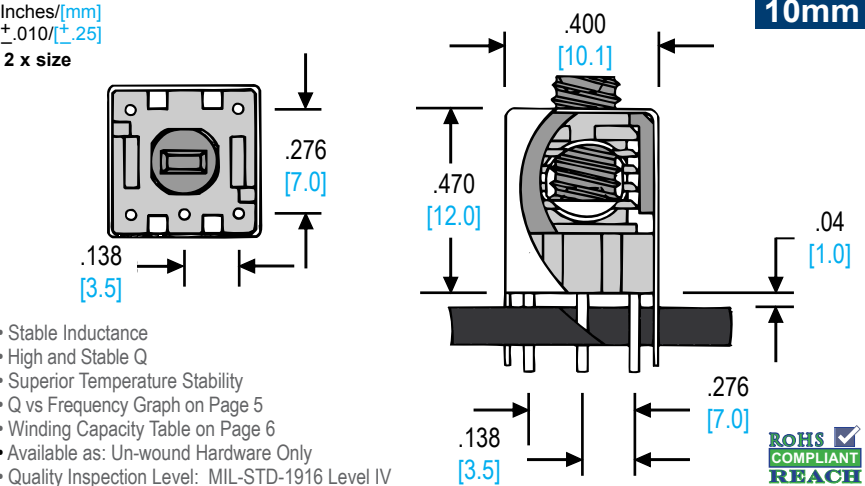

- Stable Inductance
- High and Stable Q
- Superior Temperature Stability
- Q vs Frequency Graph on Page 5
- Winding Capacity Table on Page 6
- Available as: Un-wound Hardware Only
- Quality Inspection Level: MIL-STD-1916 Level IV

10mm



ASSEMBLY PART NO.	COLOR CODE	MAGNETIC MATERIAL(1)	FREQUENCY RANGE(2)	MATERIAL PERMEABILITY	ASSEMBLY AL nH/turns ² (3)	MAX μh 100 turns	MIN μh (4) 100 turns	TEMPERATURE STABILITY(5)
L41-2-BT-F-5	RED	CARBONYL E	.25-10 MHZ	10.0	11.5	115	64	95 ppm/°C
L41-3-BT-F-5	GREY	CARBONYL HP	.02-1.0 MHZ	35.0	15	150	66	370 ppm/°C
L41-6-BT-F-5	YELLOW	CARBONYL SF	2.0-50 MHZ	8.5	10.5	105	63	35 ppm/°C
L41-10-BT-F-5	BLACK	CARBONYL W	10-100 MHZ	6.0	8	80	62	150 ppm/°C
L41-17-BT-F-5	LAVENDER	CARBONYL	20-200 MHZ	4	6	60	50	50 ppm/°C

1) The iron powder or ferrite materials are used in the tuning core and cup core.
 2) This represents the frequency range for Q optimization in tuned or resonant circuits. The inductive properties of the material is effective over a considerably wider frequency range.
 3) Nanohenries (10⁹ Henries) per turn squared.
 4) The minimum inductance is measured in microhenries (10⁶ Henries) per 100 turns with the tuning core tuned out of the winding area but still a part of the assembly.
 5) The temperature stability is of the magnetic material, measured in parts per million per degree Celsius (ppm/°C) on a toroidal core and winding. This is only an indication of the temperature stability for a complete wound assembly.

Assembly Sub-components

Actual Size

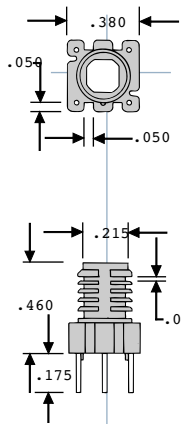

B325

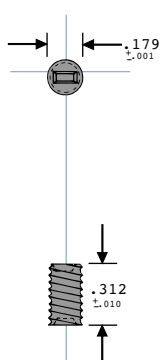

TH35-3()

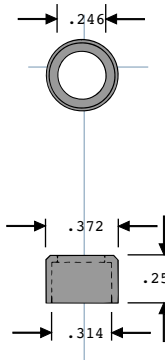

C12-40()

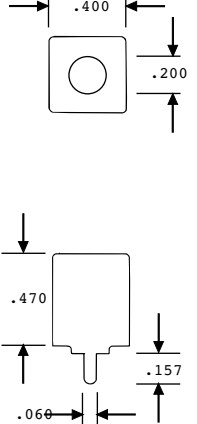

CN325BT

5 TERMINAL ASSEMBLY	BASE ONLY (6)	COLOR CODE	TUNING CORE (7)	CUP CORE	SHIELD CAN
L41-2-BT-F-5	B325	RED	TH35-302	C12-4002	CN325BT
L41-3-BT-F-5	B325	GREY	TH35-303	C12-4003	CN325BT
L41-6-BT-F-5	B325	YELLOW	TH35-306	C12-4006	CN325BT
L41-10-BT-F-5	B325	BLACK	TH35-310	C12-4010	CN325BT
L41-17-BT-F-5	B325	LAVENDER	TH35-317	C12-4017	CN325BT

6) The base and self threading segregated coil form are one piece, moulded from nylon 6/6 and will require careful heat management. The 5 terminals available are half hard brass, .025 inches in diameter, tin plated to MIL-STD 202 Method 208 for solderability.
 7) The tuning core is 10-32 shallow thread coated with Teflon.

10.5mm

L42 SERIES

Footprint

- Stable Inductance
- Very High and Stable Q
- Superior Temperature Stability
- Q vs Frequency Graph on Page 5
- Winding Capacity Table on Page 6
- Available as: Un-wound Hardware Only
- Quality Inspection Level: MIL-STD-1916 Level IV

ASSEMBLY PART NO.	COLOR CODE	MAGNETIC MATERIAL(1)	FREQUENCY RANGE(2)	MATERIAL PERMEABILITY	ASSEMBLY AL nH/turns ² (3)	MAX µH 100 turns	MIN µH (4) 100 turns	TEMPERATURE STABILITY(5)
L42-2-CT-F-2	RED	CARBONYL E	.25-1- MHZ	10.0	12.5	125	52	95 ppm/°C
L42-3-CT-F-2	GREY	CARBONYL HP	.02-1.0 MHZ	35.0	20.4	204	64	370 ppm/°C
L42-6-CT-F-2	YELLOW	CARBONYL E	2.0-50 MHZ	8.5	11.5	115	47	35 ppm/°C
L42-10-CT-F-2	BLACK	CARBONYL E	10-100 MHZ	6.0	10	100	46	150 ppm/°C
L42-17-CT-F-2	LAVENDER	CARBONYL E	20-200 MHZ	4.0	6.7	67	45	50 ppm/°C

1) The iron powder or ferrite materials are used in the tuning core and cup core.
 2) This represents the frequency range for Q optimization in tuned or resonant circuits. The inductive properties of the material is effective over a considerably wider frequency range.
 3) Nanohenries (10⁻⁹ Henries) per turn squared.
 4) The minimum inductance is measured in microhenries (10⁻⁶ Henries) per 100 turns with the tuning core tuned out of the winding area but still a part of the assembly.
 5) The temperature stability is of the magnetic material, measured in parts per million per degree Celsius (ppm/°C) on a toroidal core and winding. This is only an indication of the temperature stability for a complete wound assembly.

Assembly Sub-components

Actual Size

B342-w/PB142

CF120

PB142

B342-w/PB142

TH23-4()

C12-42 ()

CN342CT

5 TERMINAL ASSEMBLY (6)	COILFORM BASE ASSEMBLY (7)	BASE ONLY	BOBBIN WINDING FORM (8)	COLOR CODE	TUNNING CORE (9)	CUP CORE	SHIELD CAN
L42-2-CT-F-2	B342-w/PB142	B342	B342-w/PB142	RED	TH23-402	C12-4202	CN342CT
L42-3-CT-F-2	B342-w/PB142	B342	B342-w/PB142	GREY	TH23-403	C12-4203	CN342CT
L42-6-CT-F-2	B342-w/PB142	B342	B342-w/PB142	YELLOW	TH23-406	C12-4206	CN342CT
L42-10-CT-F-2	B342-w/PB142	B342	B342-w/PB142	BLACK	TH23-410	C12-4210	CN342CT
L42-17-CT-F-2	B342-w/PB142	B342	B342-w/PB142	LAVENDER	TH23-417	C12-4217	CN342CT

L42 WITH SNAP IN NYLON BOBBIN

L42(-)CT-B-2	B342-w/PB142	B342	B342-w/PB142	AS ABOVE	TH23-4()	C12-42()	CN342CT
--------------	--------------	------	--------------	----------	-----------	-----------	---------

6) The base is molded in Rynite. The base will position two tinned winding leads up to #24 AWG (.200 Dia.) for IR reflow surface mounting directly to the printed circuit board. The CF120 coilform is glass reinforced polyester tube with 8-32 internal threads. Coplanarity is not an issue due to three contact points.
 7) The optional PB142 snap in bobbin is self threading polypropylene. To order, substitute "B" for "F" in the assembly part number.
 8) The tuning core is a 8-32 shallow thread coated with Teflon.

L43 SERIES



PHOTO NOT TO SCALE

Tuned Core
Fixed Cup

11mm

Inches/[mm]
±.010/[±.25]

2 x size

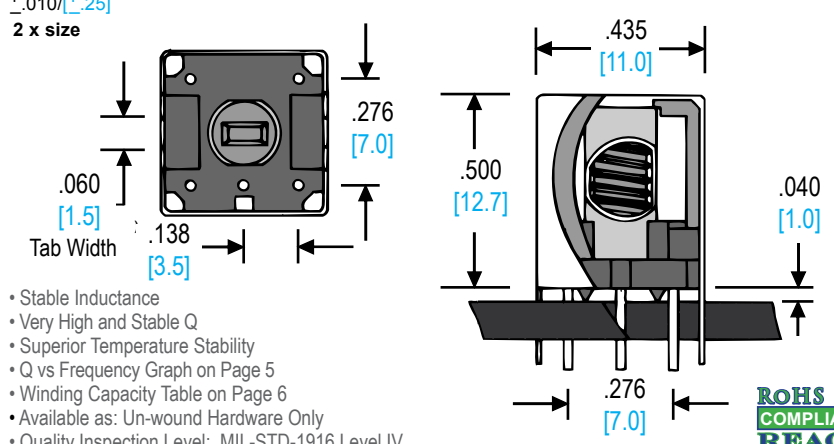

- Stable Inductance
- Very High and Stable Q
- Superior Temperature Stability
- Q vs Frequency Graph on Page 5
- Winding Capacity Table on Page 6
- Available as: Un-wound Hardware Only
- Quality Inspection Level: MIL-STD-1916 Level IV



ASSEMBLY PART NO.	COLOR CODE	MAGNETIC MATERIAL(1)	FREQUENCY RANGE(2)	MATERIAL PERMEABILITY	ASSEMBLY AL nH/turns ² (3)	MAX μH 100 turns	MIN μH (4) 100 turns	TEMPERATURE STABILITY(5)
L43-1-CT-F-5	BLUE	CARBONYL C	.15-2.0 MHz	20.0	11.5	115	54	280 ppm/°C
L43-2-CT-F-5	RED	CARBONYL E	.25-10 MHz	10.0	9.8	98	48	95 ppm/°C
L43-3-CT-F-5	GREY	CARBONYL HP	.02-1.0 MHz	35.0	13.3	133	60	370 ppm/°C
L43-6-CT-F-5	YELLOW	CARBONYL SF	2.0-50 MHz	8.5	8.5	85	44	35 ppm/°C
L43-10-CT-F-5	BLACK	CARBONYL W	10-100 MHz	6.0	7.2	72	43	150 ppm/°C
L43-17-CT-F-5	LAVENDER	CARBONYL	20-200 MHz	4.0	5.6	56	43	50 ppm/°C

1) The iron powder or ferrite materials are used in the tuning core and cup core.

2) This represents the frequency range for Q optimization in tuned or resonant circuits. The inductive properties of the material is effective over a considerably wider frequency range.

3) Nanohenries (10⁻⁹ Henries) per turn squared.

4) The minimum inductance is measured in microhenries (10⁻⁶ Henries) per 100 turns with the tuning core tuned out of the winding area but still a part of the assembly.

5) The temperature stability is of the magnetic material, measured in parts per million per degree Celsius (ppm/°C) on a toroidal core and winding. This is only an indication of the temperature stability for a complete wound assembly.

Assembly Sub-components

Actual Size

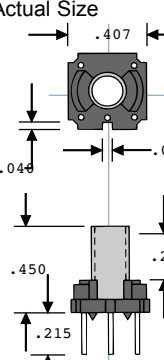

B315-w/CF112

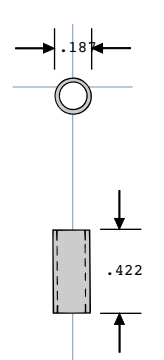

CF112

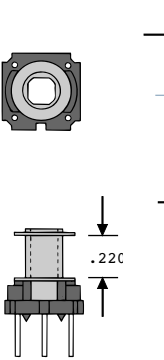

B315-w/PB114

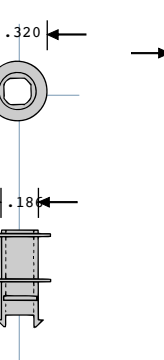

PB114

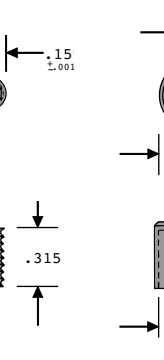

TH25-1 ()

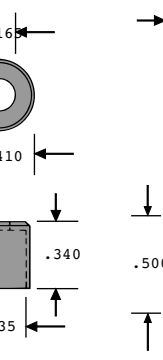

C13-40 ()

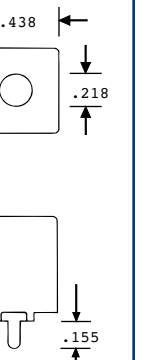

CN315CT

5 TERMINAL ASSEMBLY	BASE ONLY (6)	COIL FORM (7)	BASE ASSEMBLY	COLOR CODE	TUNING CORE (8)	CUP CORE	SHIELD CAN
L43-1-CT-F-5	B315	CF112	B315-w/CF112	BLUE	TH25-101	C13-4001	CN315CT
L43-2-CT-F-5	B315	CF112	B315-w/CF112	RED	TH25-102	C13-4002	CN315CT
L43-3-CT-F-5	B315	CF112	B315-w/CF112	GREY	TH25-103	C13-4003	CN315CT
L43-6-CT-F-5	B315	CF112	B315-w/CF112	YELLOW	TH25-106	C13-4006	CN315CT
L43-7-CT-F-5	B315	CF112	B315-w/CF112	WHITE	TH25-107	C13-4007	CN315CT
L43-10-CT-F-5	B315	CF112	B315-w/CF112	BLACK	TH25-110	C13-4010	CN315CT
L43-17-CT-F-5	B315	CF112	B315-w/CF112	LAVENDER	TH25-117	C13-4017	CN315CT
L43-50-CT-F-5	B315	CF112	B315-w/CF112	ORANGE	TH25-150	C13-4003	CN315CT
L43 WITH SNAP IN NYLON BOBBIN							
L43-()-CT-B-5	B315	PB114	B315-W/PB114	AS ABOVE	TH25-1 ()	C13-40 ()	CN315CT

6) The base is moulded from theroset Diallyl Phthalate (DAP). The 5 terminals available are half hard copper, .025 inches in diameter, tin plated to MIL-STD 202 Method 208 for solderability.

7) The CF112 coil form is a glass reinforced polyester tube with 8-32 internal threads. The PB114 snap in bobbin is self threading nylon 6/6.

8) The tuning core is 8-32 shallow thread coated with Teflon.

10mm Toko 10EZ Size

Inches/[mm]
±.010/[±.25]
2 x size

• Toko Equivalent Hardware
• Optional Capacitor Fits in Base
• Q vs Frequency Graph on Page 5
• Winding Capacity Table on Page 6
• Ferrite Drum Core and Tuned Cup
• Quality Inspection Level: MIL-STD-1916 Level IV
• Available as: Un-wound Hardware or Complete Wound Coils

L48 SERIES

Drum Core
Tuned Cup

PHOTO NOT TO SCALE

ASSEMBLY PART NO.	COLOR CODE	MAGNETIC MATERIAL(1)	FREQUENCY RANGE(2)	MATERIAL PERMEABILITY	ASSEMBLY AL. nH/turns ² (3)	MAX μH 100 turns	MIN μH (4) 100 turns	TEMPERATURE STABILITY(5)
L48-51-BT-D-5	None	FERRITE 51	.05-2.0 MHz	300	83.2	832	340	1500 ppm/°C
L48-52-BT-D-5	None	FERRITE 52	2-150 MHz	60	33.7	337	173	1500 ppm/°C

1) The ferrite materials are used in the drum core and cup core.
 2) This represents the frequency range for Q optimization in tuned or resonant circuits. The inductive properties of the material is effective over a considerably wider frequency range.
 3) Nanohenries (10⁻⁹ Henries) per turn squared.
 4) The minimum inductance is measured in microhenries (10⁻⁶ Henries) per 100 turns with the tuning core tuned out of the winding area but still a part of the assembly.
 5) The temperature stability is of the magnetic material, measured in parts per million per degree Celsius (ppm/°C) on a toroidal core and winding. This is only an indication of the temperature stability for a complete wound assembly.

Custom Wound Variable Coils

Example Part Number

Toko Style Code: L48-10EZ-L-2.0-7.96-BM
 Lodestone Part Code: L48-10EZ-C-22-10.7-A

Inductive Application: Inductance (μH), Test Freq (Mhz)
 Capacitive Application: Capacitance (pf), Self Resonant Freq (Mhz)

Winding Style: A, EK,N,N2, Z, HM, BHD, BM, YUK, M, L

Test Frequencies (Mhz): 25.2 (0.1 to 1μH), 7.96 (1μH to 10μH), 2.52 (10 to 100μH), .796 (100μH to 1mH), .252 (1mH to 10mH)

Internal Capacitors (pf): Selected to meet the specified self-resonant frequency

Inductance Range

Frequency Range

10mm Toko 10EZ Size

Custom Variable Coils are wound to your Inductance and Frequency Specifications, or with Capacitors to your Self-resonant Frequency Specifications.

Assembly Sub-components

Actual Size

5 TERMINAL ASSEMBLY	BASE with DRUM CORE (6)	COLOR CODE	DRUM CORE (8)	CUP CORE	SHIELD CAN	CAN FORM
L48-51-BT-D-5	B480	None	DR25-151	C12-8051	CN480BT	CF48
L48-52-BT-D-5	B480	None	DR25-152	C12-8052	CN480BT	CF48

6) "The base is molded in a phenolic thermoset. The attached coilform is molded in polypropylene. The 5 terminals are brass, .027 inches (0.7mm) in diameter, tin plated to meet MIL-STD 202 method 208 for solderability."
 7) The ferrite drum core is attached to the thermoset base. 8) Threaded cup matches the internal threads in the Cup Form 9) The base has a cavity for an optional capacitor. .250 [6.3mm] Long x .086 [2.2mm] Wide x .130 [3.7mm] Deep. Capacitors are not included.

L45 SERIES

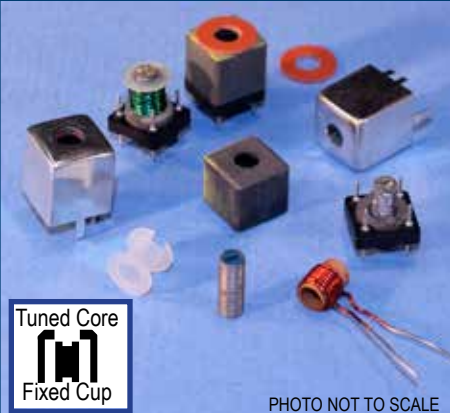

Tuned Core
Fixed Cup

PHOTO NOT TO SCALE

Inches/[mm]
±.010/±.25

2 x size

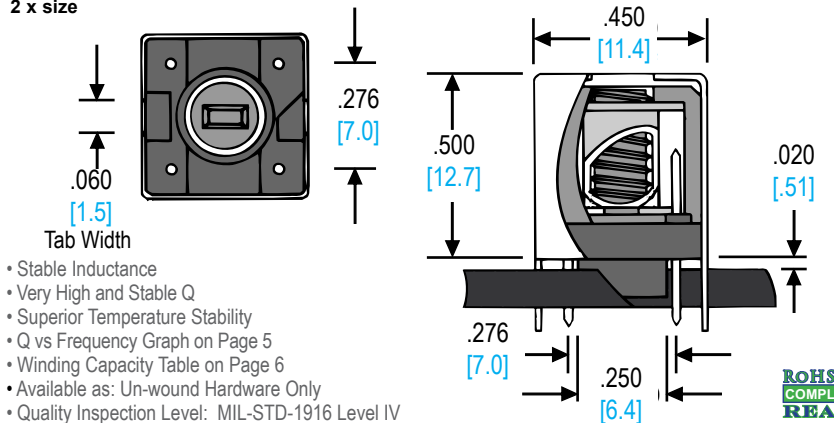

- Stable Inductance
- Very High and Stable Q
- Superior Temperature Stability
- Q vs Frequency Graph on Page 5
- Winding Capacity Table on Page 6
- Available as: Un-wound Hardware Only
- Quality Inspection Level: MIL-STD-1916 Level IV

ASSEMBLY PART NO.	COLOR CODE	MAGNETIC MATERIAL(1)	FREQUENCY RANGE(2)	MATERIAL PERMEABILITY	ASSEMBLY AL nH/turns ² (3)	MAX µh 100 turns	MIN uh (4) 100 turns	TEMPERATURE STABILITY(5)
L45-1-PCT-B-4	BLUE	CARBONYL C	.15-2.0 MHz	20.0	17.5	175	58	280 ppm/°C
L45-2-PCT-B-4	RED	CARBONYL E	.25-10 MHz	10.0	12.5	125	52	95 ppm/°C
L45-3-PCT-B-4	GREY	CARBONYL HP	.02-1.0 MHz	35.0	20.4	204	64	370 ppm/°C
L45-6-PCT-B-4	YELLOW	CARBONYL SF	2.0-50 MHz	8.5	11.5	115	47	35 ppm/°C
L45-10-PCT-B-4	BLACK	CARBONYL W	10-100 MHz	6.0	10	100	46	150 ppm/°C
L45-17-PCT-B-4	LAVENDER	CARBONYL	20-200 MHz	4.0	6.7	67	45	50 ppm/°C

1) The iron powder or ferrite materials are used in a portion of the base, the tuning core and cup core. Mix 3F is a combination of a ferrite tuning core and an iron powder cup core.
 2) This represents the frequency range for Q optimization in tuned or resonant circuits. The inductive properties of the material is effective over a considerably wider frequency range.
 3) Nanohenries (10⁻⁹ Henries) per turn squared.
 4) The minimum inductance is measured in microhenries (10⁻⁶ Henries) per 100 turns with the tuning core tuned out of the winding area but still a part of the assembly.
 5) The temperature stability is of the magnetic material, measured in parts per million per degree Celsius (ppm/°C) on a toroidal core and winding. This is only an indication of the temperature stability for a complete wound assembly.

Assembly Sub-components

Actual Size

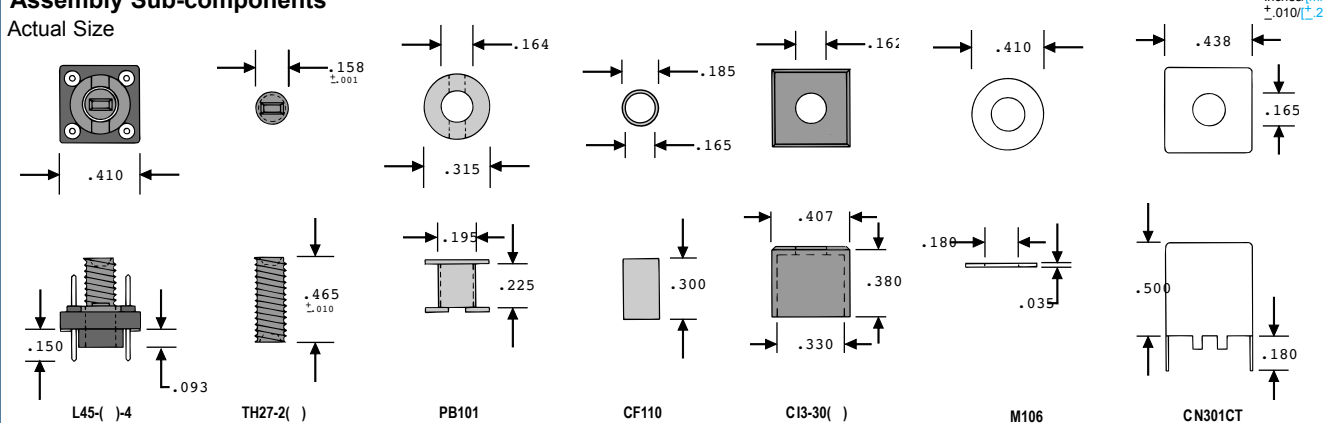

4 TERMINAL ASSEMBLY	BASE ONLY (6)	TUNING CORE (7)	BASE ASSEMBLY	COLOR CODE	WINDING FORM (8)	CUP CORE	RUBBER PAD (9)	SHIELD CAN
L45-1-PCT-B-4	B300-1	TH27-201	L45-1-4	BLUE	PB101	C13-3001	M106	CN301CT
L45-2-PCT-B-4	B300-2	TH27-202	L45-2-4	RED	PB101	C13-3002	M106	CN301CT
L45-3-PCT-B-4	B300-3	TH27-203	L45-3-4	GREY	PB101	C13-3003	M106	CN301CT
L45-3F-PCT-B-4	B300-3	TH27-268	L45-3F-4	GREY/ORANGE	PB101	C13-3003	M106	CN301CT
L45-6-PCT-B-4	B300-6	TH27-206	L45-6-4	YELLOW	PB101	C13-3006	M106	CN301CT
L45-10-PCT-B-4	B300-10	TH27-210	L45-10-4	BLACK	PB101	C13-3010	M106	CN301CT
L45-17-PCT-B-4	B300-17	TH27-217	L45-17-4	LAVENDER	PB101	C13-3017	M106	CN301CT

4 TERMINAL ASSEMBLY WITH PAPER COIL FORM

L4501-()-PCT-F-4	B300-()	TH27-2()	L4501-()-4	AS ABOVE	CF110	C13-30()	M106	CN301CT
-------------------	----------	-----------	-------------	----------	-------	-----------	------	---------

6) The base is moulded from therosmet Diallyl Phthalate (DAP). The 4 terminals available are half hard brass, .024 inches in diameter, tin plated to MIL-STD 202 Method 208 for solderability.
 7) The tuning core is 8-40 shallow thread coated with Teflon.
 8) The winding bobbin PB101 is moulded nylon 6/6. CF110 is a phenolic impregnated paper tube.
 9) The anti-vibration silicon rubber pad M106 is optional. It will be excluded from assemblies when the "P" is excluded from the assembly number. (ie: L45-2-CT-B-4)

14.5mm

• Stable Inductance
• Very High and Stable Q
• Superior Temperature Stability
• Q vs Frequency Graph on Page 5
• Winding Capacity Table on Page 6
• Available as: Un-wound Hardware Only
• Quality Inspection Level: MIL-STD-1916 Level IV

L57 SERIES

PHOTO NOT TO SCALE

Tuned Core
Fixed Cup

ASSEMBLY PART NO.	COLOR CODE	MAGNETIC MATERIAL (1)	FREQUENCY RANGE (2)	MATERIAL PERMEABILITY	ASSEMBLY AL. nH/turns ² (3)	MAX μh 100 turns	MIN μh (4) 100 turns	TEMPERATURE STABILITY (5)
L57-1-PCT-B-4	BLUE	CARBONYL C	.15-2.0 Mhz	20.0	18.5	185	60	280 ppm/°C
L57-2-PCT-B-4	RED	CARBONYL E	.25-10 Mhz	10.0	13.0	130	54	95 ppm/°C
L57-3-PCT-B-4	GREY	CARBONYL HP	.02-1.0 Mhz	35.0	21.5	215	70	370 ppm/°C
L57-6-PCT-B-4	YELLOW	CARBONYL SF	10-50 Mhz	8.5	12.0	120	51	35 ppm/°C
L57-10-PCT-B-4	BLACK	CARBONYL W	10-100 Mhz	6.0	10.5	105	50	150 ppm/°C
L57-17-PCT-B-4	LAVENDER	CARBONYL	20-200 Mhz	4.0	7.0	70	50	50 ppm/°C

1) The iron powder or ferrite materials are used in a portion of the base, the tuning core and cup core. Mix 3F is a combination of a ferrite tuning core and an iron powder cup core.

2) This represents the frequency range for Q optimization in tuned or resonant circuits. The inductive properties of the material is effective over a considerably wider frequency range.

3) Nanohenries (10⁻⁹ Henries) per turn squared.

4) The minimum inductance is measured in microhenries (10⁻⁶ Henries) per 100 turns with the tuning core tuned out of the winding area but still a part of the assembly.

5) The temperature stability is of the magnetic material, measured in parts per million per degree Celsius (ppm/°C) on a toroidal core and winding. This is only an indication of the temperature stability for a complete wound assembly.

Assembly Sub-components

Actual Size

4 TERMINAL ASSEMBLY	BASE ONLY (6)	TUNING CORE (7)	BASE ASSEMBLY	COLOR CODE	WINDING FORM (8)	CUP CORE	RUBBER PAD (9)	SHIELD CAN
L57-1-PCT-B-4	B202-1	TH27-201	L57-1-4	BLUE	PB100	C17-2101	M107	CN101CT
L57-2-PCT-B-4	B202-2	TH27-202	L57-2-4	RED	PB100	C17-2102	M107	CN101CT
L57-3-PCT-B-4	B202-3	TH27-203	L57-3-4	GREY	PB100	C17-2103	M107	CN101CT
L57-3F-PCT-B-4	B202-3	TH27-268	L57-3F-4	GREY/ORANGE	PB100	C17-2103	M107	CN101CT
L57-6-PCT-B-4	B202-6	TH27-206	L57-6-4	YELLOW	PB100	C17-2106	M107	CN101CT
L57-10-PCT-B-4	B202-10	TH27-210	L57-10-4	BLACK	PB100	C17-2110	M107	CN101CT
L57-17-PCT-B-4	B202-17	TH27-217	L57-17-4	LAVENDER	PB100	C17-2117	M107	CN101CT

4 TERMINAL ASSEMBLY WITH PAPER COIL FORM								
L5701(-) J-PCT-F-4	B202-()	TH27-2()	L5701(-) J-4	AS ABOVE	CF110	C17-21()	M107	CN101CT

6 TERMINAL ASSEMBLY								
L57(-) J-PCT-B-6	B200-()	TH27-2()	L57(-) J-6	AS ABOVE	PB100	C17-21()	M107	CN101CT

6 TERMINAL ASSEMBLY WITH PAPER COIL FORM								
L5701(-) J-PCT-F-6	B200-()	TH27-2()	L5701(-) J-6	AS ABOVE	CF110	C17-21()	M107	CN101CT

6) The base is moulded from thermoset Diallyl Phthalate (DAP). The 4 or 6 terminals available are half hard brass, .032 inches in diameter, tin plated to MIL-STD 202 Method 208 for solderability.

7) The tuning core is 8-40 shallow thread coated with Teflon.

8) The winding bobbin PB100 is moulded nylon 6/6. CF110 is a phenolic impregnated paper tube.

9) The anti-vibration silicon rubber pad M107 is optional. It will be excluded from assemblies when the "P" is excluded from the assembly number. (ie: L57-2-CT-B-4)

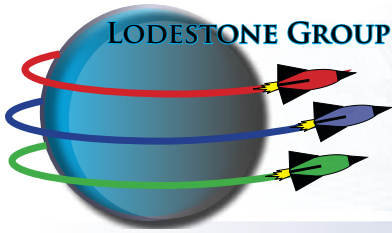

LODESTONE GROUP

LODESTONE GROUP

Low Price • High Quality • Exceptional Service
Diverse Skills • Broad Experience • Quality Products

LODESTONE PACIFIC

Finest In The Field

- Plastic Molded Bobbins
- Plastic Molded Toroid Mounts
- Through Hole and Surface Mount
- Plastic Molded Anti-static Parts Trays
- Terminal Lead Frames and Terminal Pins
- Metal Stamping, Forming and CNC Cutting
- Fair-Rite Products Ferrites
- Micrometals Iron Powder Cores
- Micrometals Alloy Powder Cores
- P. Leo Transformer Insulation Tape
- CAD/CAM Technology
- Custom Plastic Molding
- Cost Effective Custom Tooling
- In-House 3D Printing of Prototypes
- World Class Quality Systems and Logistics



TOROID MOUNTS AND HEADERS

POWDER AND FERRITE CORE MATERIAL



TRANSFORMER TAPE & BOBBINS

REED-REX

Distributor of Kofu (OKI) Reed Switches

- High Quality Reed Switches
- 7, 10, 12, 14, 16, & 21 mm sizes
- "Ask the Expert" Technical Support
- Cross Reference to Other Manufacturers
- Reed Switches in Stock and Ready to Ship

Distributor of Standex-Meder

- Coil Activated Reed Relays
- Custom Plastic Molded Enclosures
- Magnetic Field Activated Reed Sensors
- Sensors & Relays in Stock and Ready to Ship



DIGILANT.net

Product Design and Fabrication

- Quality China Product Sourcing
- PCB Design, Fabrication and Stuffing
- CAD/CAM Design and Experience
- In-House 3D Printing of Prototypes
- Bending and Stamping of Metal Parts
- Precision Aluminum & Mg Die Casting
- Custom CNC Fabrication of All Metals
- Electronic and Mechanical Assemblies
- PCB Gerber File Design and Production
- USA & China Quality Control and Inspection
- Warehouse, Logistics & Freight Consolidation

